

# GWC Italia

Proven technology  
for individual valve solutions  
worldwide



**FLANGED FLOATING BALL VALVES**

FBV-1002

The GWC logo consists of the letters 'GWC' in a bold, blue, sans-serif font. A registered trademark symbol (®) is located at the top right of the 'C'. The logo is set against a white background.



**TABLE OF CONTENTS**

<b>GWC Italia Worldwide Network</b>	<b>4</b>
<b>Company Overview, Certifications &amp; Standards</b>	<b>5</b>
<b>Split Body Ball Valves</b>	<b>6</b>
<b>Unibody Ball Valves</b>	<b>7</b>
<b>Ordering Guide</b>	<b>9</b>

**Standard Features**

<b>Unibody Floating Ball Valve - Model A</b>	<b>10</b>
<b>Split Body Floating Ball Valve - Model B</b>	<b>11</b>
<b>Split Body Floating Ball Valve - Model C</b>	<b>12</b>
<b>Top Works Dimension Model A</b>	<b>14</b>
<b>Top Works Dimension Model B</b>	<b>16</b>
<b>Top Works Dimension Model C</b>	<b>18</b>
<b>Technical Characteristics</b>	<b>20</b>

# GWC Italia

## Worldwide Network

**ITALY GROUP HEADQUARTERS, PRODUCTION & SALES**  
GWC Italia, SpA  
Via A. Grandi, 5  
20056 Trezzo Sull'Adda  
Milano, Italy  
Phone: 39-02-86882941  
Fax: 39-02-86882942  
Email: sales@gwcitalia.com



California

Texas

Italia

U.A.E.

China



**USA HEADQUARTERS PRODUCTION & SALES**

GWC USA, Inc.  
8502 Crippen Street  
Bakersfield, CA. 93313  
ph: +1-661.834.1775  
fax: +1-661.834.2072  
Email: sales@gwcitalia-usa.com



**SALES**

GWC USA, Inc  
24624 Interstate 45 N.  
Spring, Texas 77386  
Toll Free: +1.877.768.3760  
ph: +1.281.719-1986  
Email: sales@gwcitalia-usa.com



**SALES**

GWC Valve & Controls DMCC,  
Dubai  
1506, Platinum Tower  
I-Cluster,  
Jumeirah Lake Towers  
Dubai UAE  
ph: +971-44.539.358  
Email: sales@gwcitalia.com



**PRODUCTION & SALES**

GWC Valve Manufacturing  
(Shanghai) Co., Ltd.  
No 3600 Jihe Rd,  
Huaxin Town,  
Qingpu, Shanghai 201708,  
China  
ph: +86-21.597.987.99  
fax: +86-21.597.987.90  
Email: sales@gwcitalia.com

**GWC Italia SpA** with its Headquarters in Milan, Italy designs, manufacturers and markets valves with one of the most extensive lines you will find in the Industry today. GWC Italia SpA which is founded by an Italian Group & USA Entrepreneurial Management team, has become the Parent Company of the long standing GWC Worldwide Companies. This Italian & USA team has a history of building and managing successful valve manufacturing companies over the past 40 years. The valves manufactured in Italy will be complementary to the existing GWC line consisting of diversified flow control packages in a variety of alloys, trims, configurations, sizes and pressure classes, from general to severe applications. GWC Valves are used in major applications for Upstream, Downstream & Transportation Segments of the Oil & Gas Industry, E&P, Petrochemical, Chemical, Mining/Minerals, Power, Marine and Industrial markets.

**GWC Italia SpA extensive line of valve and flow control products include but not limited to:**

- Trunnion Mounted Ball Valves (soft & metal seated)
  - Split Body
  - Top Entry
  - Welded Body
  - Subsea
  - Cryogenic & High Temperature
  - Two Balls One Body DBBV
- Pipeline Gate and Check Valves
- Floating Ball Valves
- Gate, Globe and Check Valves including Cast & Forged
- Butterfly Valves including Triple Offset, High Performance and Resilient Seated
- Dual Plate Check Valves
- Needle and Gauge Valves
- Wellhead Gate Valves

GWC Italia Spa products are designed, engineered and manufactured to exceed its customer's stringent process requirements including API 6D, API 6A, API 6DSS, API 600, API 602, API 608, ISO 9001, PED, ATEX, SIL 3 and TA – Luft.



**Proven technology  
for individual valve solutions  
worldwide**

## CERTIFICATIONS & STANDARDS

### American Standards

#### American Petroleum Institute

API-6D	Specification for Pipeline Valves
API-6D SS	Specification for Subsea Pipeline Valves
API-6A	Specification for Wellhead and Christmas Tree Equipment
API-6FA	Specification for Fire Test for Valves
API-594	Check Valves: Wafer, Wafer-Lug, and Double Flanged Type
API-598	Valve Inspection and Testing
API-600	Bolted Bonnet Steel Gate Valves for Petroleum and Natural Gas Industries
API-602	Compact Steel Gate Valves- Flanged, Threaded, Welding and Extended-Body Ends
API-607	Fire Test for Soft-Seated Quarter-Turn Valves
API-608	Metal Ball Valves - Flanged, Threaded, and Welding End
API-609	Butterfly Valves: Double Flanged, Lug and Wafer-Type
API-Q1	Specification for Quality Programs for the Petroleum, Petrochemical & Natural Gas

#### American Society of Mechanical Engineers

ASME-B1.20.1	Pipe Threads, General Purpose (inch)
ASME-B16.11	Forged Fittings, Socket-Welding and Threaded
ASME-B16.10	Face to Face and End to End Dimensions of Valves
ASME-B16.5	Pipe Flanges and Flanged Fittings NPS 1/2 ~ NPS 24
ASME-B16.47	Large Diameter Steel Flanges NPS 26 ~ NPS 60
ASME-B16.25	Buttwelding Ends
ASME-B16.34	Valves - Flanged, Threaded and Welding End

### International Standards

ISO 9001:2008	Quality Management Systems
ISO 14001	Environmental Management
OHSAS 18001:2007	Occupational Health and Safety Management System
ISO/TS 29001	Petroleum, Petrochemical and Natural Gas Industries - Sector Specific Quality Management Systems
CE/PED	Pressure Equipment Directive
CU-TR	Technical Reglament Conformity Certificate TRCU
CRN	Canadian Registration Number
Z245.15.96	Pipeline Steel Valves
ATEX	European for explosive atmosphere
SIL3	Measurement of performance required for safety instrument function

**STANDARD FEATURES - Split Body Ball Valves**

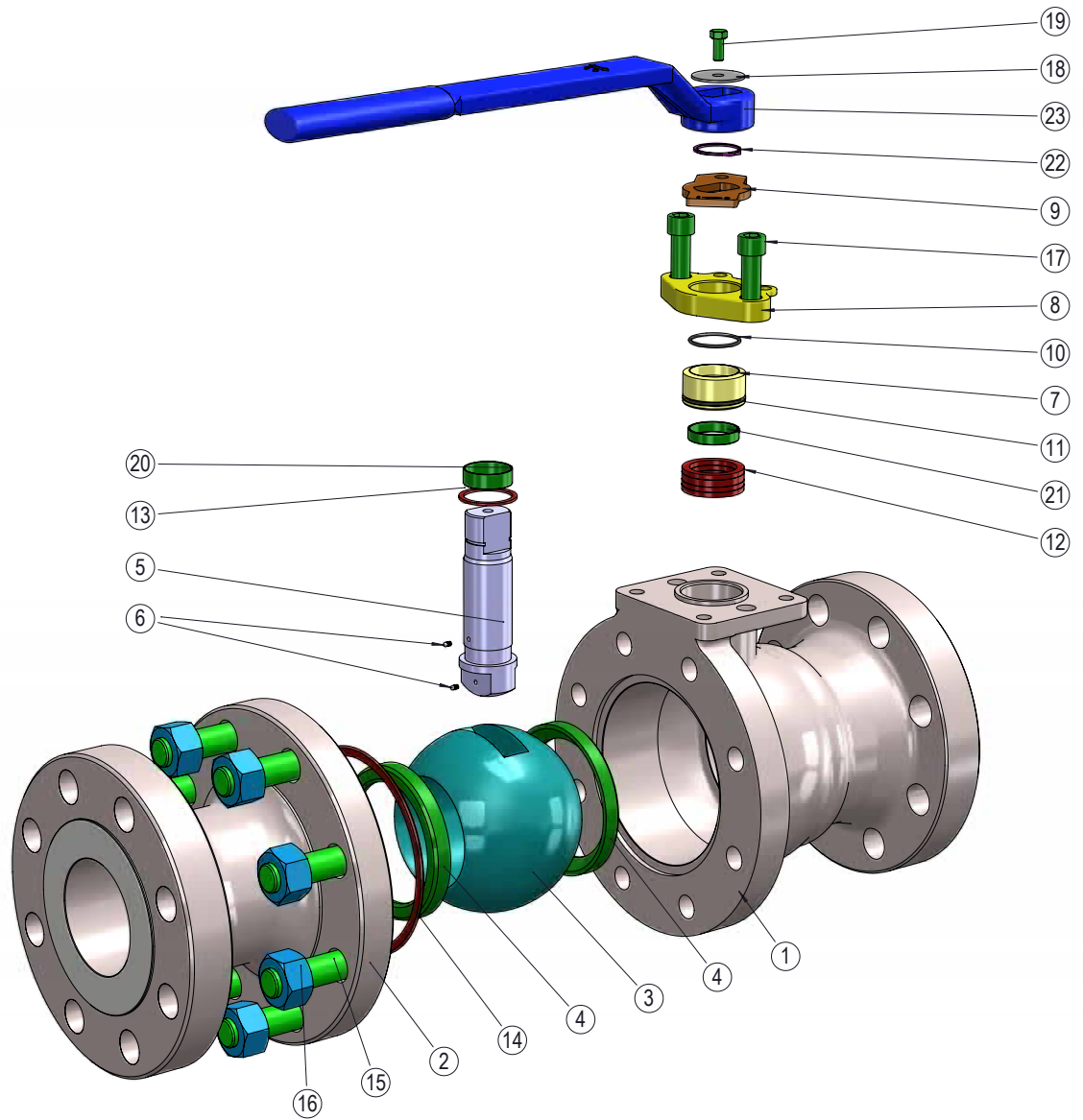

The GWC SPLIT BODY ball valves are designed, constructed and tested according to the most recent international standards, such as API, ASME, BS, DIN, etc.

- |                                |                          |                         |
|--------------------------------|--------------------------|-------------------------|
| 1. Body                        | 9. Combination Lock Stop | 17. Gland Screw         |
| 2. Closure / Cap               | 10. Stem O-Ring          | 18. Stem Washer         |
| 3. Ball                        | 11. Gland O-Ring         | 19. Stem Bolt           |
| 4. Cavity Relieving Seat       | 12. Packing              | 20. Stem Bearing        |
| 5. Stem                        | 13. Stem Thrust Washer   | 21. Gland Bearing       |
| 6. Anti-Static Spring and Ball | 14. Spiral Wound Gasket  | 22. Snap Ring / Circlip |
| 7. Gland Bushing               | 15. Body Stud            | 23. Handle              |
| 8. Gland Flange                | 16. Body Nut             |                         |

## STANDARD FEATURES — Unibody Ball Valves

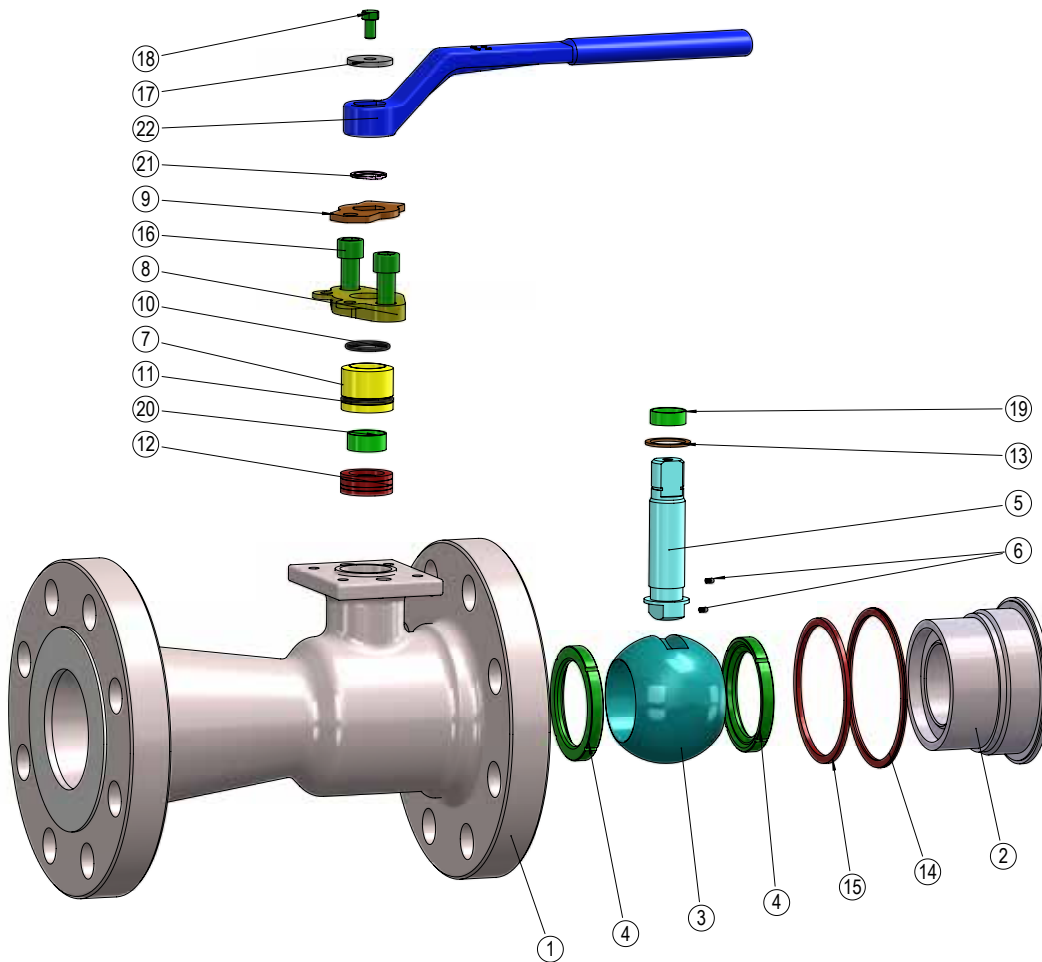

The GWC UNIBODY ball valves are designed, constructed and tested according to the most recent international standards, such as API, ASME, BS, DIN, etc.

- |                                |                        |                         |
|--------------------------------|------------------------|-------------------------|
| 1. Body                        | 10. Stem O-Ring        | 19. Stem Bearing        |
| 2. Closure / Cap               | 11. Gland O-Ring       | 20. Gland Bearing       |
| 3. Ball                        | 12. Packing            | 21. Snap Ring / Circlip |
| 4. Cavity Relieving Seat       | 13. Stem Thrust Washer | 22. Handle              |
| 5. Stem                        | 14. Graphite Gasket    |                         |
| 6. Anti-Static Spring and Ball | 15. PTFE Gasket        |                         |
| 7. Gland Bushing               | 16. Gland Screw        |                         |
| 8. Gland Flange                | 17. Stem Washer        |                         |
| 9. Combination Lock Stop       | 18. Stem Bolt          |                         |

**SPLIT BODY & UNIBODY BALL VALVES**

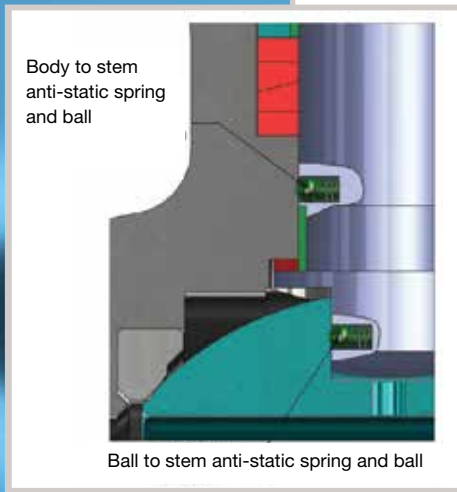
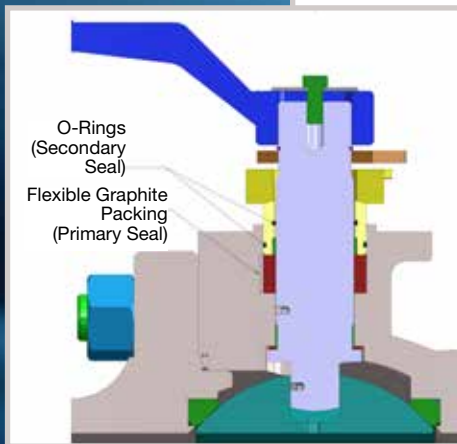
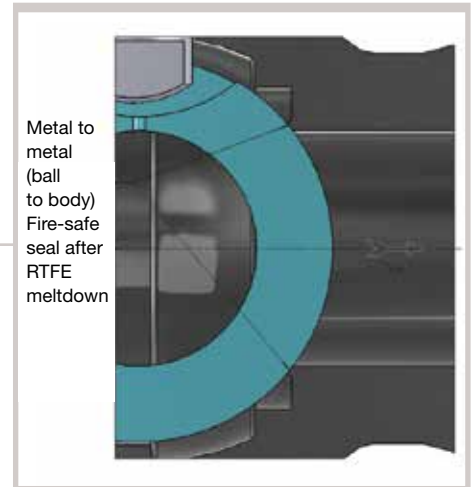

**Figure 1**

Ball valves present a particular problem with the build up of static electricity around the ball. All GWC ball valves have anti-static devices which provides contact between stem and ball, and stem and body to eliminate static electricity.

**Figure 2**

In the event of a fire the valve is required to make a downstream seal. Even after the disintegration of the RTFE seats, GWC ball valves have an excellent metal to metal seal.

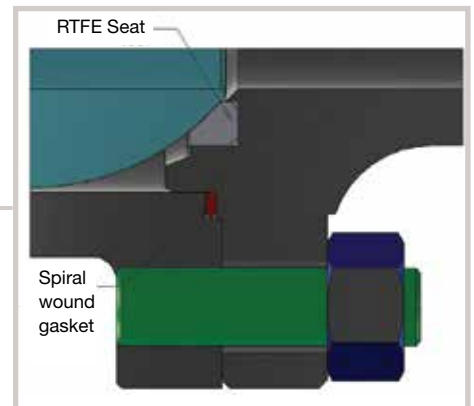

**Figure 3**

The combination of stem packing and o-rings guarantee zero emissions even at a low pressure. The primary seal is made out of flexible graphite, a material with extremely good resistance to fire conditions. The anti-blow out stem is inserted from inside the valve body.

**Figure 4**

Special attention has been paid to the mechanical strength and sealing efficiency of the central flanged joint in the valve body.



**Figure 5 (unibody only)**

The PTFE gasket packing acts as a primary seal for the Unibody ball valves. The secondary seal has been made out of flexible graphite, a material with extremely good resistance to fire conditions.

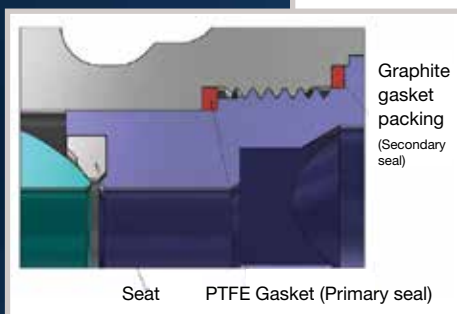



# ORDERING GUIDE

## Example: 4" Figure B150-1-BC-G2-L

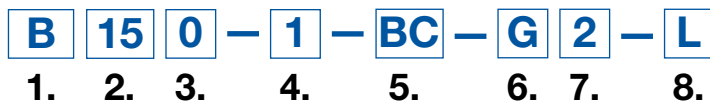

4" CLASS 150 FLOATING BALL VALVE, FLG-RF, FULL BORE, A216 WCB BODY x 316SS TRIM, RTFE SEAT, VITON-B O-RINGS, NACE, FIRESAFE, LEVER OP.

### 1. MODEL

A - FLOATING BALL, UNIBODY, REDUCED BORE	C - FLOATING BALL, SPLIT BODY, REDUCED BORE
B - FLOATING BALL, SPLIT BODY, FULL BORE	

### 2. RATING

15 - CLASS 150	90 - CLASS 900 *
30 - CLASS 300	150 - CLASS 1500 *
60 - CLASS 600	* 1/2" - 1" SIZES ONLY

### 3. END CONNECTION

0 - RF FLANGED	9 - RING JOINT
7 - BUTTWELD (SCHEDULE REQUIRED)	X - SPECIAL

### 4. TYPE

1 - FIRE-SAFE

### 5. MATERIAL (BODY + TRIM )

AC - WCB + 304	HC - LCB + LF2/ENP	NC - CF3M + 316L
BC - WCB + 316	IC - LCB + F6A/13CR	OC - CN7M + A/20
CC - WCB + A105/ENP	JC - LCB + 316	PC - A890-4A + F51
DC - WCB + F6A/13CR	KC - CF8 + 304	QC - A890-5A + F53
EC - LCC + LF2/ENP	LC - CF8M + 316	RC - A890-6A + F55
FC - LCC + F6A/13CR	MC - CF3 + 304L	X - SPECIAL
GC - LCC + 316		

### 6. MATERIAL (SEAT)

G - RTFE	V - PEEK	X - SPECIAL
B - NYLON	J - DELRIN	
E - DEVLON	M - METAL	

### 7. MATERIAL (O-RING SEAL)

1 - HNBR	4 - EPDM	7 - GRAPHITE
2 - VITON -B	5 - AFLAS	X - SPECIAL
3 - VITON-GLT	6 - PTFE	

### 8. OPERATOR

L - HANDWHEEL OPERATOR	GO - WORM GEAR OPERATOR	B - BARE STEM
------------------------	-------------------------	---------------

### 9. SPECIAL REQUIREMENTS

EB - EXTENDED BONNET	S - SUPPLY COMPLETE INFORMATION
----------------------	---------------------------------

## UNIBODY FLOATING BALL VALVE – Model A150/A300



### Construction

Unibody, reduced bore, free floating ball, fire-safe certified to API-607, blow-out proof stem, cavity relieving seats, anti-static device, designed and tested according to ASME B16.34, BS5351 and API-6D.

### Dimension

Face to Face	ASME B16.10 Short Pattern
End Flange	ASME B16.5
Rating	ASME Class 150-300

\*\*NACE MR-01-75 Certified\*\*

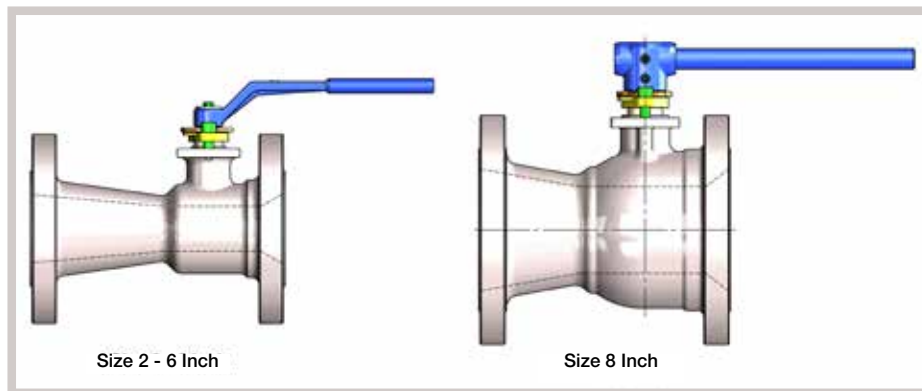
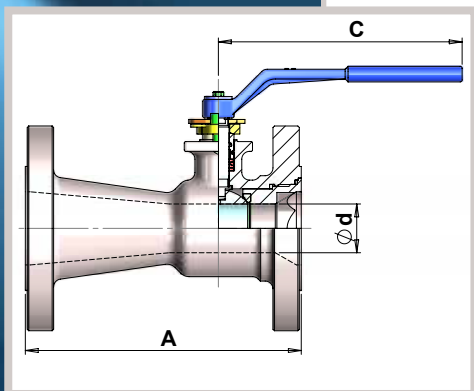

### Standard Materials

Fig. No.	A150-1-BC-G1-L, A300-1-BC-G1-L	A150-1-LC-G1-L, A300-1-LC-G1-L
Body/Retainer	A216 WCB	A351 CF8M
Ball/Stem	316SS	316SS
Seats	RTFE	RTFE
O-Rings	HNBR	HNBR

### Class 150

DIMENSIONS IN INCHES					
VALVE SIZE	2" 50mm	3" 80mm	4" 100mm	6" 150mm	8" 200mm
Bore Size (d)	1.50	2.50	3.00	4.00	6.00
Face to Face (A)	7.00	8.00	9.00	10.50	11.50
Length of Lever (C)	9.84	9.84	13.78	18.11	-
Approx. Weight (lbs.)	16	28	54	84	160

### Class 300

DIMENSIONS IN INCHES					
VALVE SIZE	2" 50mm	3" 80mm	4" 100mm	6" 150mm	8" 200mm
Bore Size (d)	1.50	2.00	3.00	4.00	6.00
Face to Face (A)	8.50	11.15	12.00	15.88	16.50
Length of Lever (C)	9.84	9.84	13.78	18.11	-
Approx. Weight (lbs.)	24	50	85	132	200

## SPLIT BODY FLOATING BALL VALVE — Model B150/B300

### Construction

Split body, full bore, free floating ball, fire-safe certified to API-607, blow-out proof stem, cavity relieving seats, anti-static device, designed and tested according to ASME B16.34, BS5351 and API-6D.

### Dimension

Face to Face	ASME B16.10 Long Pattern
End Flange	ASME B16.5
Rating	ASME Class 150-300

\*\*NACE MR-01-75 Certified\*\*

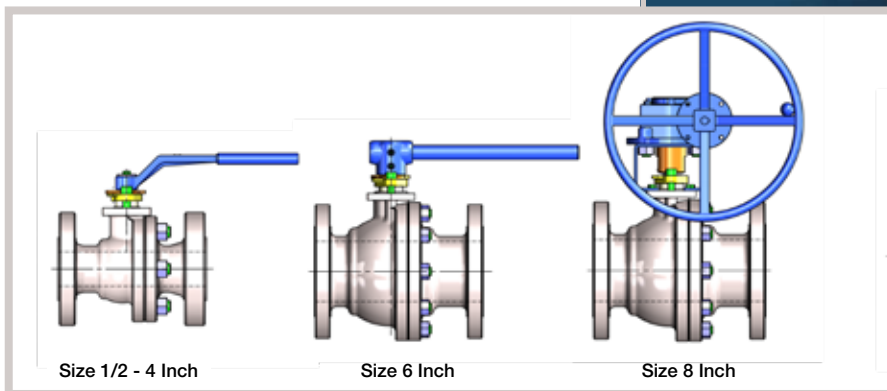
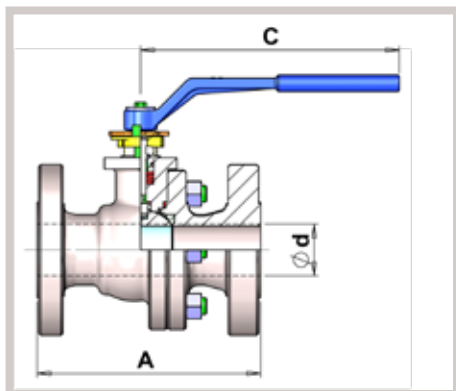

### Standard Materials

Fig. No.	B150-1-BC-G1-L, B300-1-BC-G1-L	B150-1-LC-G1-L, B300-1-LC-G1-L
Body/Retainer	A216 WCB	A351 CF8M
Ball/Stem	316SS	316SS
Seats	RTFE	RTFE
O-Rings	HNBR	HNBR

### Class 150

DIMENSIONS IN INCHES										
VALVE SIZE	1/2" 15mm	3/4" 20mm	1" 25mm	1-1/2" 40mm	2" 50mm	2-1/2" 65mm	3" 80mm	4" 100mm	6" 150mm	8" 200mm
Bore Size (d)	0.50	0.75	1.00	1.50	2.00	2.50	3.00	4.00	6.00	8.00
Face to Face (A)	4.25	4.625	5.00	6.50	7.00	7.50	8.00	9.00	15.50	18.00
Length of Lever (C)	5.91	5.91	5.91	9.84	9.84	9.84	13.78	18.11	29.53	-
Wheel Diameter (F)	-	-	-	-	-	-	-	-	-	23.62
Approx. Weight (lbs.)	5	7	10	20	26	35	56	80	172	378

### Class 300

DIMENSIONS IN INCHES										
VALVE SIZE	1/2" 15mm	3/4" 20mm	1" 25mm	1-1/2" 40mm	2" 50mm	3" 80mm	4" 100mm	6" 150mm	8" 200mm	
Bore Size (d)	0.50	0.75	1.00	1.50	2.00	3.00	4.00	6.00	8.00	
Face to Face (A)	5.50	6.00	6.50	7.50	8.50	11.125	12.00	15.875	19.75	
Length of Lever (C)	5.91	5.91	5.91	9.84	9.84	13.78	18.11	29.53	-	
Wheel Diameter (F)	-	-	-	-	-	-	-	-	23.62	
Approx. Weight (lbs.)	9	11	15	28	38	75	110	230	481	

**SPLIT BODY FLOATING BALL VALVE — C150/C300**



**Construction**

Split body, reduced bore, free floating ball, fire-safe certified to API-607, blow-out proof stem, cavity relieving seats, anti-static device, designed and tested according to ASME B16.34, BS5351 and API-6D.

**Dimension**

Face to Face	ASME B16.10 Short Pattern
End Flange	ASME B16.5
Rating	ASME Class 150-300

\*\*NACE MR-01-75 Certified\*\*

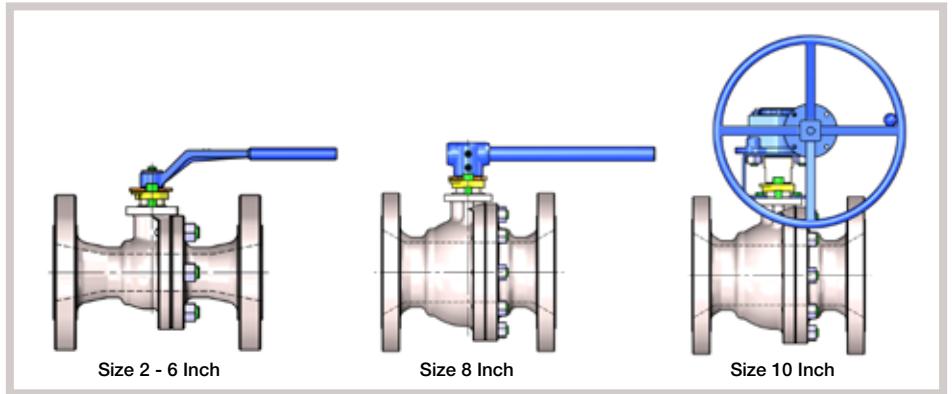
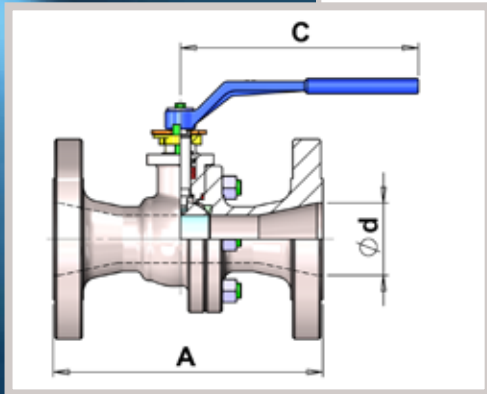

**Standard Materials**

Fig. No.	C150-1-BC-G1-L, C300-1-BC-G1-L	C150-1-LC-G1-L, C300-1-LC-G1-L
Body/Cap	A216 WCB	A351 CF8M
Ball/Stem	316SS	316SS
Seats	RTFE	RTFE
O-Rings	HNBR	HNBR

**Class 150**

DIMENSIONS IN INCHES						
VALVE SIZE	2" 50mm	3" 80mm	4" 100mm	6" 150mm	8" 200mm	10" 250mm
Bore Size (d)	1.50	2.00	3.00	4.00	6.00	8.00
Face to Face (A)	7.00	8.00	9.00	10.50	11.50	13.00
Length of Lever (C)	9.84	9.84	13.80	18.10	29.50	-
Wheel Diameter (F)	-	-	-	-	-	23.62
Approx. Weight (lbs.)	21	48	69	124	189	446

**Class 300**

DIMENSIONS IN INCHES						
VALVE SIZE	2" 50mm	3" 80mm	4" 100mm	6" 150mm	8" 200mm	10" 250mm
Bore Size (d)	1.50	2.00	3.00	4.00	6.00	8.00
Face to Face (A)	8.50	11.125	12.00	15.875	16.50	18.00
Length of Lever (C)	9.84	9.84	13.80	18.10	29.50	-
Wheel Diameter (F)	-	-	-	-	-	23.62
Approx. Weight (lbs.)	30	58	97	208	370	581

## SPLIT BODY FLOATING BALL VALVE — Model B600/C600

### Construction

Split body, full bore or reduced bore, free floating ball, fire-safe certified to API-607, blow-out proof stem, cavity relieving seats, anti-static device, designed and tested according to ASME B16.34, BS5351 and API-6D.

### Dimension

Face to Face	ASME B16.10 Long Pattern
End Flange	ASME B16.5
Rating	ASME Class 600

\*\*NACE MR-01-75 Certified\*\*

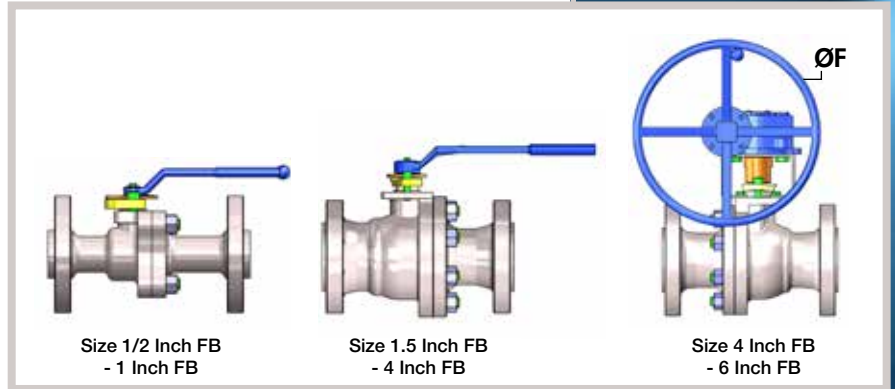
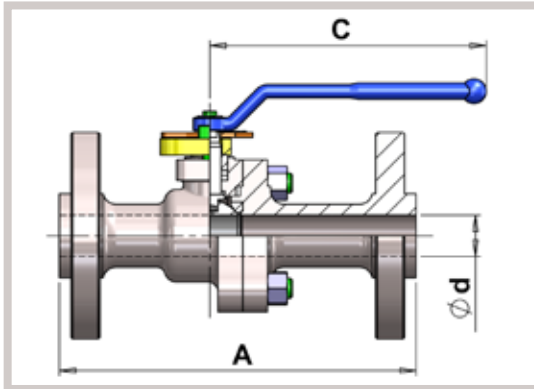

### Standard Materials

Fig. No.	B600-1-BC-J1-L, C600-1-BC-J1-L	B600-1-LC-J1-L, C600-1-LC-J1-L
Body/Cap	A216 WCB	A351 CF8M
Ball/Stem	316SS	316SS
Seats	DELTRIN	DELTRIN
O-Rings	HNBR	HNBR

### Class 600 — Full Bore

DIMENSIONS IN INCHES								
VALVE SIZE		1/2" 15mm	3/4" 20mm	1" 25mm	1-1/2" 40mm	2" 50mm	3" 80mm	4" 100mm
Bore Size (d)		0.50	0.75	1.00	1.50	2.00	3.00	4.00
Face to Face (A)	RF	6.50	7.50	8.50	9.50	11.50	14.00	17.00
	RTJ	6.50	7.50	8.50	9.50	11.62	14.12	17.12
Length of Lever (C)		5.90	5.90	5.90	17.13	17.13	21.65	-
Wheel Diameter (F)		-	-	-	-	-	-	18.11
Approx. Weight (lbs.)		10	12	16	31	44	104	183

### Class 600 — Reduced Bore

DIMENSIONS IN INCHES					
VALVE SIZE		2" 50mm	3" 80mm	4" 100mm	6" 150mm
Bore Size (d)		1.50	2.00	3.00	4.00
Face to Face (A)	RF	11.50	14.00	17.00	22.00
	RTJ	11.62	14.12	17.12	22.11
Length of Lever (C)		17.13	17.13	21.65	-
Wheel Diameter (F)		-	-	-	18.11
Approx. Weight (lbs.)		42	81	131	271

**TOP WORKS DIMENSION - MODEL A**

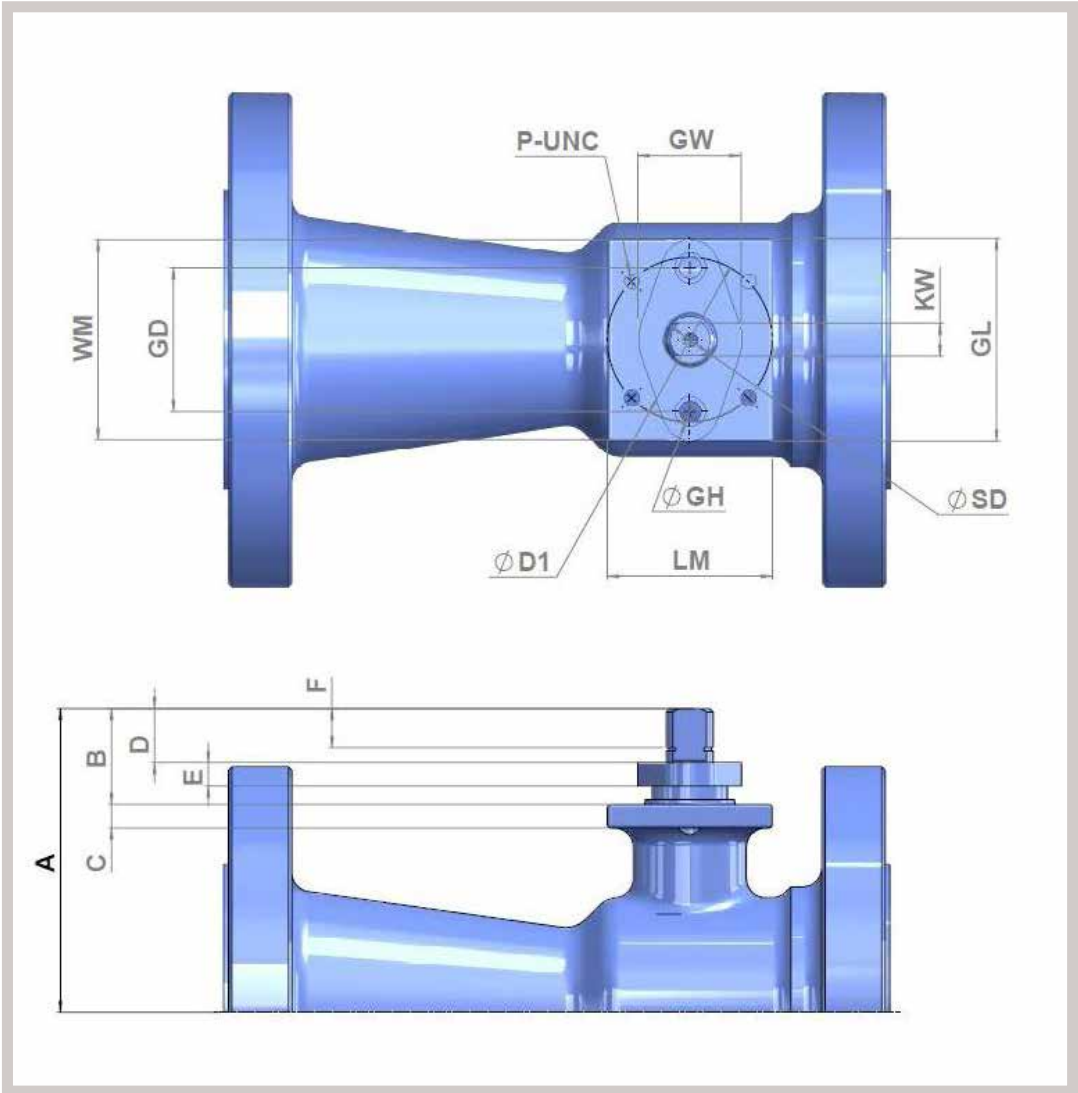

**TOP WORKS DIMENSION FOR MODEL A - INCH**

Size	CLASS	A	B	C	D	E	F	WM	GD	GW	P-UNC	KW	GL	LM	ØSD	ØGH	ØD1	MSS SP-101 TYPE
2" x 1.5" [DN 50 X DN40]	150	4.1	1.5	0.4	0.8	0.4	0.6	3.4	2.4	1.7	4-5/16	0.6	3.4	2.8	0.8	0.7	2.8	FA07
	300	4.1	1.5	0.4	0.8	0.4	0.6	3.4	2.4	1.7	4-5/16	0.6	3.4	2.8	0.8	0.7	2.8	FA07
3" x 2" [DN 80 X DN40]	150	4.7	1.6	0.4	0.9	0.4	0.6	3.4	2.4	1.7	4-5/16	0.6	3.4	2.8	0.8	0.7	2.8	FA07
	300	4.7	1.6	0.4	0.9	0.4	0.6	3.4	2.4	1.7	4-5/16	0.6	3.4	2.8	0.8	0.7	2.8	FA07
4" x 3" [DN 100 X DN 80]	150	6.6	2.1	0.6	1.1	0.6	0.7	4.0	2.9	2.2	4-3/8	0.8	4.0	3.7	1.2	0.7	4.0	FA10
	300	6.6	2.1	0.6	1.1	0.6	0.7	4.0	2.9	2.2	4-3/8	0.8	4.0	3.7	1.2	0.7	4.0	FA10
6" x 4" [DN 150 X DN 100]	150	7.2	2.1	0.6	1.1	0.6	0.7	4.0	2.9	2.2	4-3/8	0.8	4.0	3.7	1.2	0.7	4.0	FA10
	300	7.2	2.1	0.6	1.1	0.6	0.7	4.0	2.9	2.2	4-3/8	0.8	4.0	3.7	1.2	0.7	4.0	FA10

**TOP WORKS DIMENSION FOR MODEL A - MM**

Size	CLASS	A	B	C	D	E	F	WM	GD	GW	P-UNC	KW	GL	LM	ØSD	ØGH	ØD1	MSS SP-101 TYPE
2" x 1.5" [DN 50 X DN40]	150	103.5	39.0	10.5	20.4	10.0	14.8	86.0	61.0	44.0	4-5/16	14.0	86.0	70.0	19.8	17.0	70	FA07
	300	103.5	39.0	10.5	20.4	10.0	14.8	86.0	61.0	44.0	4-5/16	14.0	86.0	70.0	19.8	17.0	70	FA07
3" x 2" [DN 80 X DN40]	150	120.5	41.0	10.5	22.4	10.0	16.5	86.0	61.0	44.0	4-5/16	14.0	86.0	70.0	19.8	17.0	70	FA07
	300	120.5	41.0	10.5	22.4	10.0	16.5	86.0	61.0	44.0	4-5/16	14.0	86.0	70.0	19.8	17.0	70	FA07
4" x 3" [DN 100 X DN 80]	150	168.0	53.0	12.0	27.1	14.0	18.5	102.0	74.0	56.0	4-3/8	20.0	102.0	95.0	29.8	19.0	102	FA10
	300	168.0	53.0	12.0	27.1	14.0	18.5	102.0	74.0	56.0	4-3/8	20.0	102.0	95.0	29.8	19.0	102	FA10
6" x 4" [DN 150 X DN 100]	150	183.0	53.0	12.0	27.9	14.0	18.5	102.0	74.0	56.0	4-3/8	20.0	102.0	95.0	29.8	19.0	102	FA10
	300	183.0	53.0	12.0	27.9	14.0	18.5	102.0	74.0	56.0	4-3/8	20.0	102.0	95.0	29.8	19.0	102	FA10

**TOP WORKS DIMENSION - MODEL B**

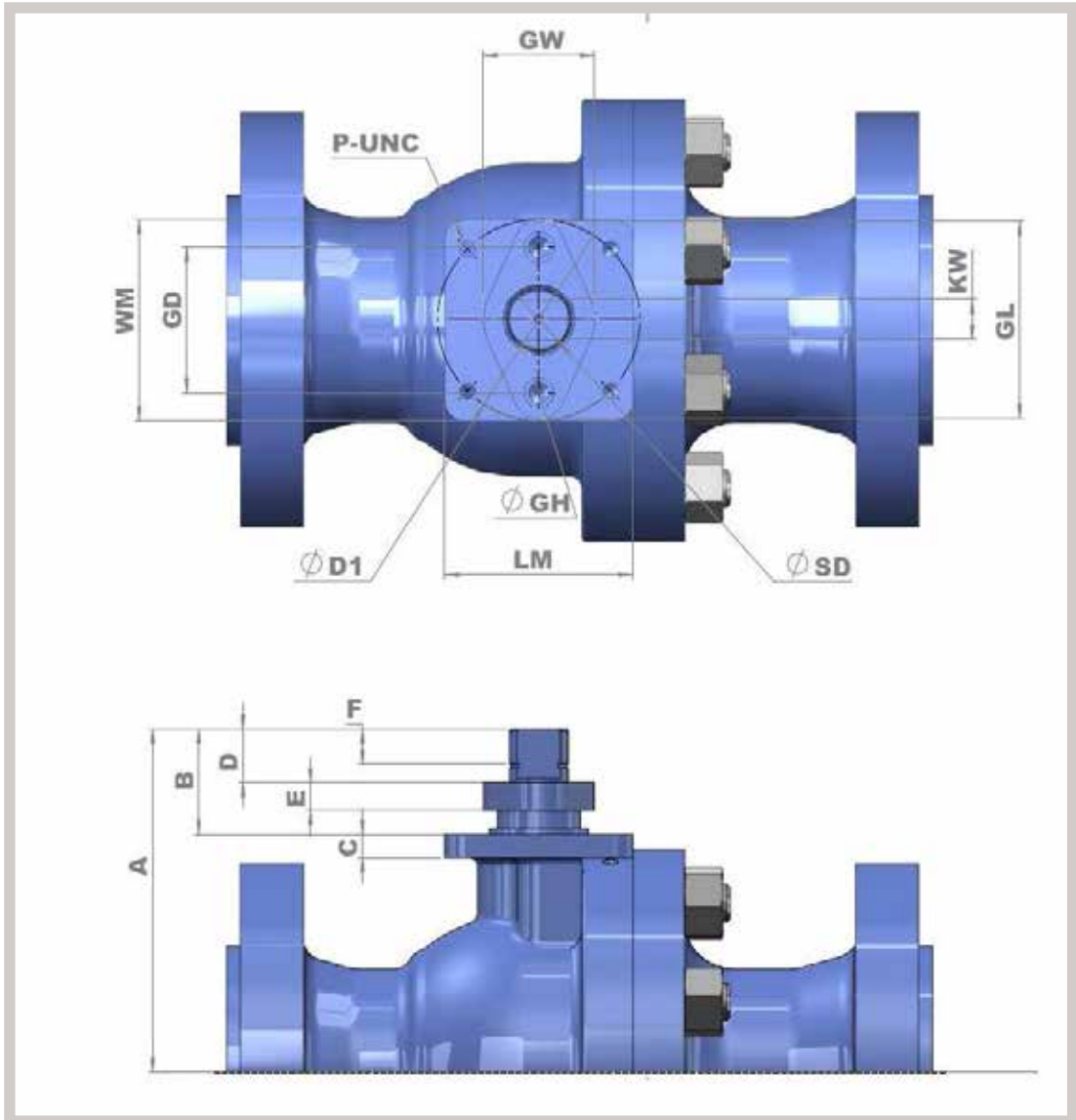





**TOP WORKS DIMENSION - MODEL C**

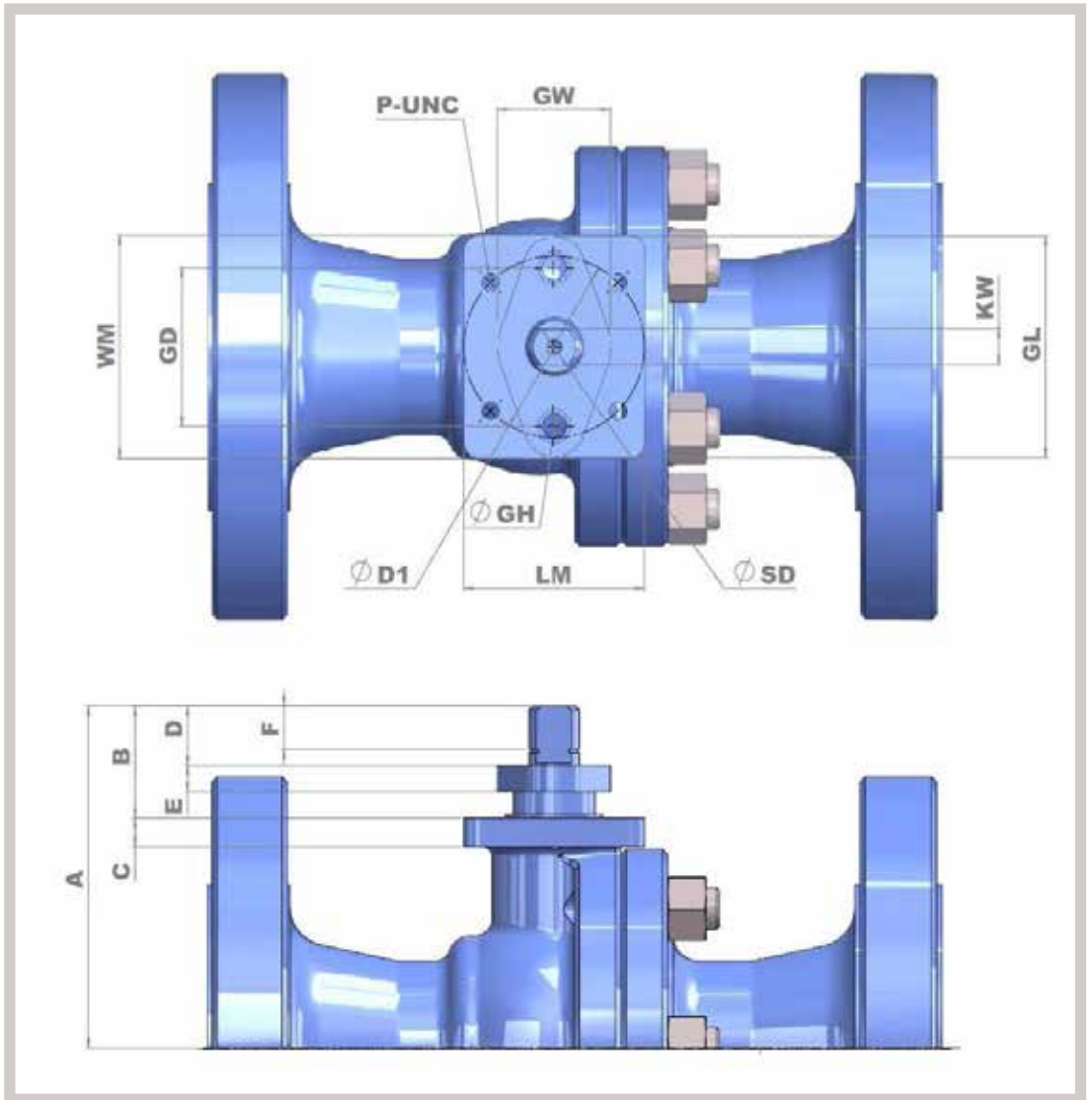

TOP WORKS DIMENSION FOR MODEL C - INCH

Size	CLASS	A	B	C	D	E	F	WM	GD	GW	P-UNC	KW	GL	LM	ØSD	ØGH	ØD1	MSS SP-101 TYPE
2" x 1.5" [DN 50 x DN 40]	150	4.1	1.5	0.4	0.8	0.4	0.6	3.4	2.4	1.7	4-5/16	0.6	3.3	2.8	0.8	0.6	2.8	FA07
	300	4.1	1.5	0.4	0.8	0.4	0.6	3.4	2.4	1.7	4-5/16	0.6	3.3	2.8	0.8	0.6	2.8	FA07
	600	4.1	1.5	0.5	0.8	0.4	0.6	3.4	2.4	1.7	4-5/16	0.6	3.3	2.8	0.8	0.6	2.8	FA07
3" x 2" [DN 80 x DN 50]	150	4.8	1.5	0.4	0.9	0.4	0.6	3.4	2.4	1.7	4-5/16	0.6	3.3	2.8	0.8	0.6	2.8	FA07
	300	5.0	1.5	0.4	0.9	0.4	0.6	3.4	2.4	1.7	4-5/16	0.6	3.3	2.8	0.8	0.6	2.8	FA07
	600	4.9	1.5	0.6	0.9	0.4	0.6	3.7	2.4	1.7	4-5/16	0.6	3.3	3.0	0.8	0.6	2.8	FA07
4" x 3" [DN 100 x DN 80]	150	6.6	2.1	0.5	1.1	0.6	0.7	4.0	2.9	2.2	4-3/8	0.8	3.9	3.7	1.2	0.7	4.0	FA10
	300	6.6	2.1	0.5	1.1	0.6	0.7	4.0	2.9	2.2	4-3/8	0.8	3.9	3.7	1.2	0.7	4.0	FA10
	600	6.8	2.1	0.5	1.1	0.6	0.7	4.0	2.9	2.2	4-3/8	0.8	3.9	3.7	1.2	0.7	4.0	FA10
6" x 4" [DN 150 x DN 100]	150	7.4	2.1	0.5	1.1	0.6	0.7	4.0	2.9	2.2	4-3/8	0.8	3.9	3.7	1.2	0.7	4.0	FA10
	300	7.4	2.1	0.5	1.1	0.6	0.7	4.0	2.9	2.2	4-3/8	0.8	3.9	3.7	1.2	0.7	4.0	FA10
	600	9.0	3.0	0.6	1.6	0.7	1.2	5.2	3.9	3.1	4-1/2	1.2	5.2	4.5	1.6	0.9	4.9	FA12
8" x 6" [DN 200 x DN 150]	150	10.3	3.0	0.6	1.6	0.7	1.2	5.2	3.9	3.1	4-1/2	1.2	5.2	4.5	1.6	0.9	4.9	FA12
	300	10.3	3.0	0.6	1.7	0.7	1.2	5.2	3.9	3.1	4-1/2	1.2	5.2	4.5	1.6	0.9	4.9	FA12
10" x 8" [DN 250 x DN 200]	150	12.6	3.1	0.7	1.7	0.9	1.2	5.9	4.4	3.3	4-5/8	1.4	5.7	5.3	2.0	0.9	5.5	FA14
	300	12.6	3.1	0.7	1.9	0.9	1.2	5.9	4.4	3.3	4-5/8	1.4	5.7	5.3	2.0	0.9	5.5	FA14

TOP WORKS DIMENSION FOR MODEL C - MM

Size	CLASS	A	B	C	D	E	F	WM	GD	GW	P-UNC	KW	GL	LM	ØSD	ØGH	ØD1	MSS SP-101 TYPE
2" x 1.5" [DN 50 x DN 40]	150	103.5	39.0	10.5	20.4	10.0	14.3	86.0	61.0	44.0	4-5/16	14.0	85.0	70.0	19.8	16.5	70	FA07
	300	103.5	39.0	10.5	20.4	10.0	14.3	86.0	61.0	44.0	4-5/16	14.0	85.0	70.0	19.8	16.5	70	FA07
	600	103.5	37.0	12.0	19.9	10.0	14.3	86.0	61.0	44.0	4-5/16	14.0	85.0	70.0	19.8	16.0	70	FA07
3" x 2" [DN 80 x DN 50]	150	122.0	38.0	9.5	21.8	10.0	16.3	86.0	61.0	44.0	4-5/16	14.0	85.0	70.0	19.8	16.5	70	FA07
	300	128.0	39.0	11.0	22.8	10.0	16.3	86.0	61.0	44.0	4-5/16	14.0	85.0	70.0	19.8	16.5	70	FA07
	600	124.5	38.5	16.0	22.3	10.0	16.3	94.0	61.0	44.0	4-5/16	14.0	85.0	76.0	19.8	16.0	70	FA07
4" x 3" [DN 100 x DN 80]	150	168.0	53.0	12.0	27.1	14.0	17.7	102.0	74.0	56.0	4-3/8	20.0	100.0	95.0	29.8	19.0	102	FA10
	300	168.0	53.0	12.0	27.1	14.0	17.7	102.0	74.0	56.0	4-3/8	20.0	100.0	95.0	29.8	19.0	102	FA10
	600	173.0	53.0	12.0	27.1	14.0	17.7	102.0	74.0	56.0	4-3/8	20.0	100.0	95.0	29.8	18.0	102	FA10
6" x 4" [DN 150 x DN 100]	150	188.0	53.0	12.0	27.9	14.0	17.7	102.0	74.0	56.0	4-3/8	20.0	100.0	95.0	29.8	19.0	102	FA10
	300	188.0	53.0	12.0	27.9	14.0	17.7	102.0	74.0	56.0	4-3/8	20.0	100.0	95.0	29.8	19.0	102	FA10
	600	229.0	75.5	16.0	41.1	18.0	29.5	133.0	100.0	78.0	4-1/2	30.0	132.0	114.0	39.8	24.0	125	FA12
8" x 6" [DN 200 x DN 150]	150	262.0	75.5	16.0	41.1	18.0	29.5	133.0	100.0	78.0	4-1/2	30.0	132.0	114.0	39.8	24.0	125	FA12
	300	262.0	75.5	16.0	43.1	18.0	29.5	133.0	100.0	78.0	4-1/2	30.0	132.0	114.0	39.8	24.0	125	FA12
10" x 8" [DN 250 x DN 200]	150	319.0	79.0	18.0	42.6	22.0	30.3	150.0	113.0	85.0	4-5/8	36.0	145.0	134.0	49.8	24.0	140	FA14
	300	319.0	79.0	18.0	48.4	22.0	30.3	150.0	113.0	85.0	4-5/8	36.0	145.0	134.0	49.8	24.0	140	FA14

## TECHNICAL CHARACTERISTICS

### PRESSURE / TEMPERATURE CHART

The following chart indicates the pressure and temperature ratings for commonly used seat material used in ASME 150# – 600# GWC floating ball valves. Other materials are available upon request.

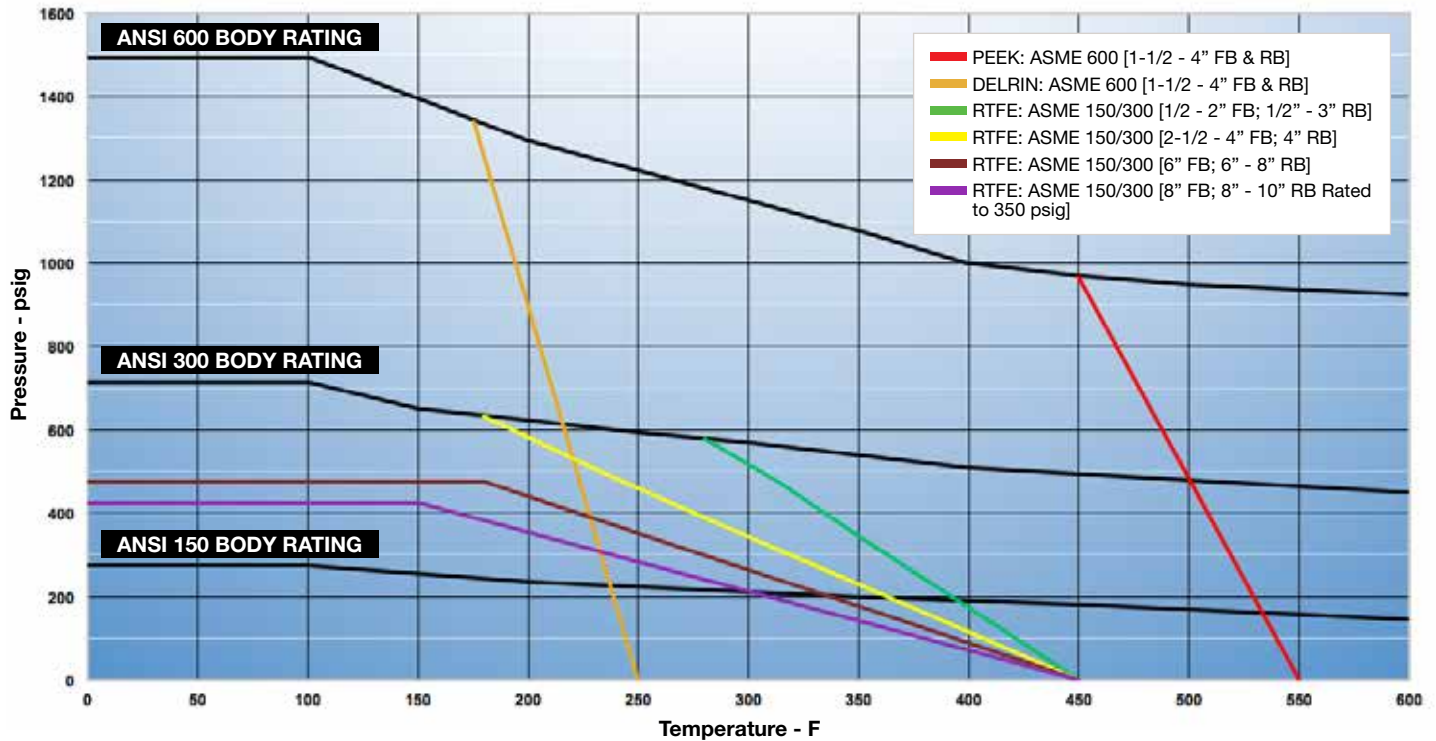

### TORQUE VALUES [INCH-LBS]

BORE Size (In.)	ANSI Class#		
	150	300	600
	Pressure (PSI)		
	285 PSI	740 PSI	1480 PSI
1/2" FP	48	60	204
3/4" FP	60	84	324
1" FP	132	240	540
1-1/2" FP 2" RP	180	264	1140
2" FP 3" RP	240	492	1332
2-1/2" FP	372	852	-
3" FP 4" RP	624	1500	3144
4" FP 6" RP	1332	2916	6912
6" FP 8" RP	4944	11064	-
8" FP 10" RP	9996	25092	-

\* No Safety factor added in the above torque. GWC recommends Min. 25% (or) more to be considered based on application.

### FLANGED FLOATING VALVE Cv VALUES

Cv is a number measured in gallons/minute, which is calculated from the flow of water through the valve with a 1 psi pressure drop across the valve length.

SIZE (In.)	ANSI Class#		
	150	300	600
1/2" FP	20	20	20
3/4" FP	50	50	50
1" FP	95	95	95
1-1/2" FP 2" RP	240 133	240 133	240 133
2" FP 3" RP	460 245	460 245	460 245
2-1/2" FP	720	720	-
3" FP 4" RP	1150 590	1150 590	1150 590
4" FP 6" RP	2125 850	2125 850	2125 850
6" FP 8" RP	5450 2200	5450 2200	- -
8" FP 10" RP	10225 3900	10225 3900	- -









**WORLDWIDE  
HEADQUARTERS**

**GWC Italia SpA**

Via A. Grandi, 5  
20056 Trezzo Sull'Adda  
Milano, Italy  
**ph:** 39-02-86882941  
**fax:** 39-02-86882942

**USA HEADQUARTERS**

**GWC USA, Inc.**

4301 Yeager Way  
Bakersfield,  
California 93313 - USA  
**ph:** 661-834-1775  
**fax:** 661-834-2072

[www.gwcitalia.com](http://www.gwcitalia.com)