

# The DuraSeal™

4-Way Diverter Valve

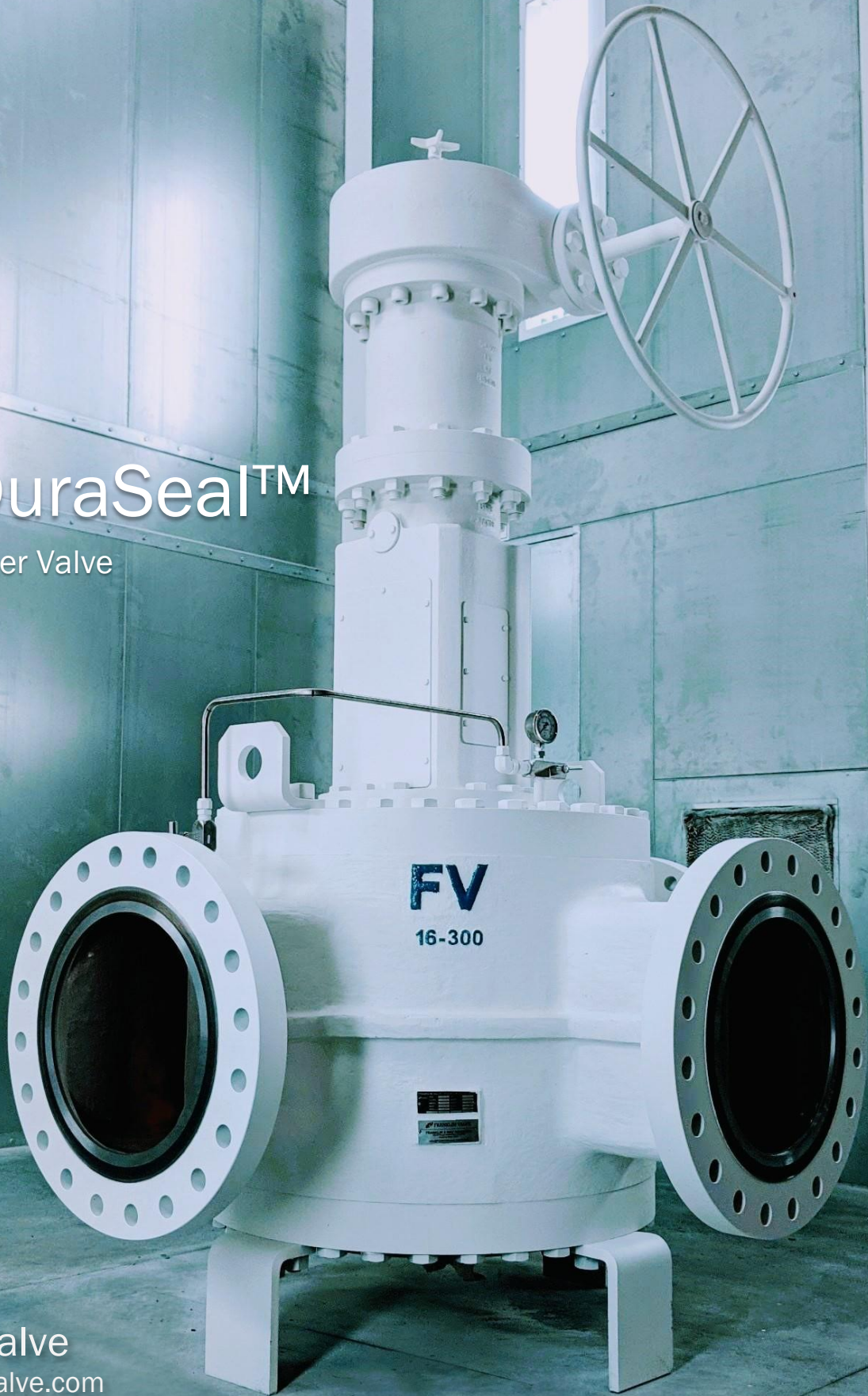

# The DuraSeal™ 4-Way Diverter Valve

---

The DuraSeal™ 4-Way Diverter Valve is a mechanically seated, non-lubricated expanding plug style valve that provides a provable bubble tight seal while diverting product flow direction. At Franklin, we understand the criticality of product isolation during measurement and multi-product storage, and in response, have designed our diverter valve with proven performance and quality features that allow for consistent performance even in the most demanding service conditions. You can always rely on Franklin's commitment to manufacture, deliver and service the valves that meet your challenging requirements.

The DuraSeal™ 4-Way meets the following product requirements:

- ASTM B16.34
- ASME B16.5
- PED/CE by request
- PESR/UKCA by request
- CRN (Canada) certified
- Designed, assembled and tested in an ISO 9001 certified/API Q1 compliant facility

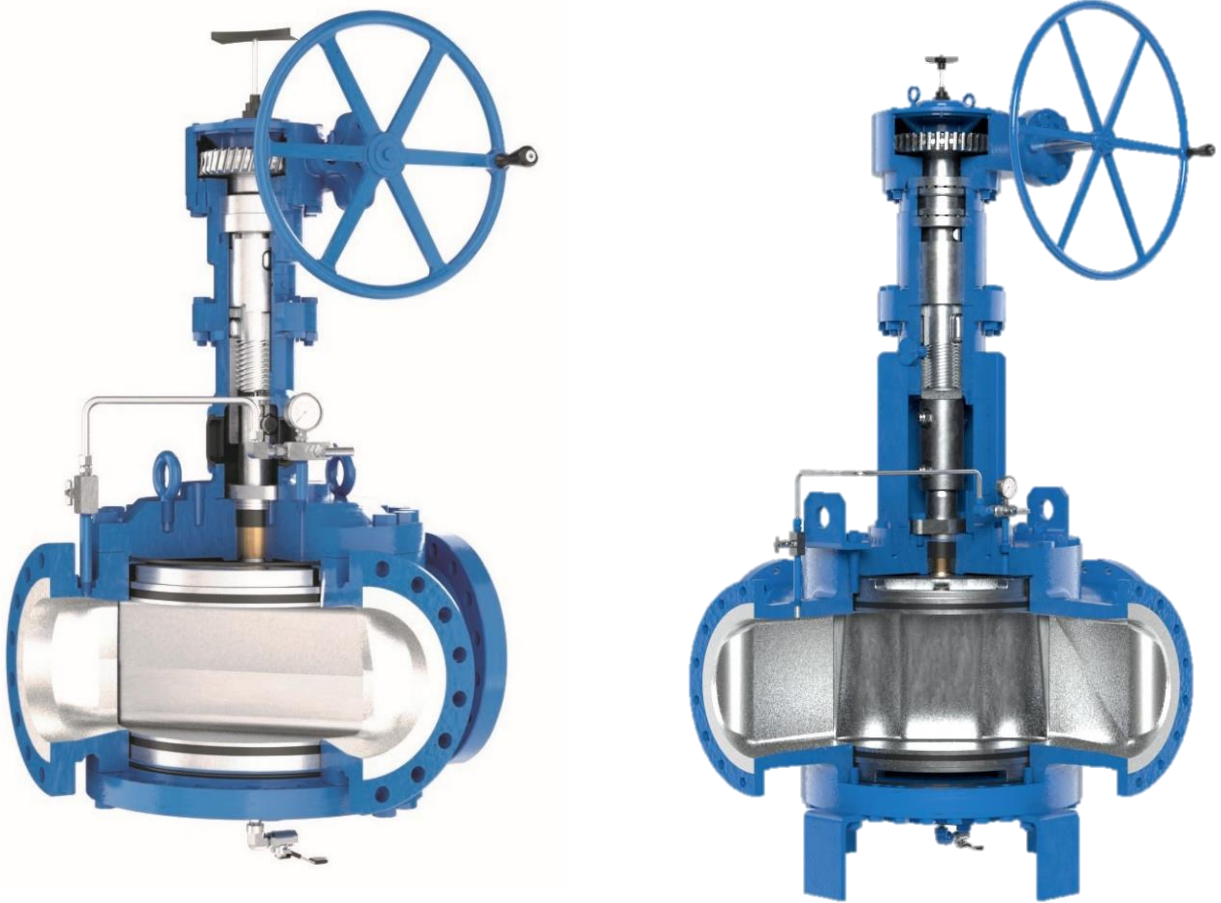

# Table of Contents

---

Company History	2
How the DuraSeal™ 4-Way Diverter Valve Works	3
Features & Benefits	4
Applications	5
DuraSeal™ 4-Way Diverter Valve - Internal View	6
Standard Materials of Construction Q411, Q431 & Q461	7
Preferred Mounting Positions	8
Q400 Series ANSI 150, 300, 600 – Worm Gear Operated	9
Q400 Series ANSI 150, 300, 600 – Gear Operated	10
Q400 Series ANSI 150, 300, 600 - Flow Coefficients (CV) and Torque & Turns	11
Actuator Adaption-Gear Operator Mounting	12
DTR - Standard Configuration	13

---



# Company History

Since 2005, Franklin Valve has been on a mission to supply the oil & gas industry with a quality product, while also leading the industry in customer service and delivery. In 2014 we moved into our current facility, allowing us to better leverage our large inventory and lean manufacturing practices while expanding on our Engineering and R&D capabilities, all with the goal of better serving customer needs.

As we've grown, our **Value Proposition** has remained the same: Franklin Valve offers the highest value on product quality and customer service while leveraging our large inventories to meet and exceed customer lead times. Franklin Valve is globally distributed, represented and approved with high profile end users and Original Equipment Manufacturers.

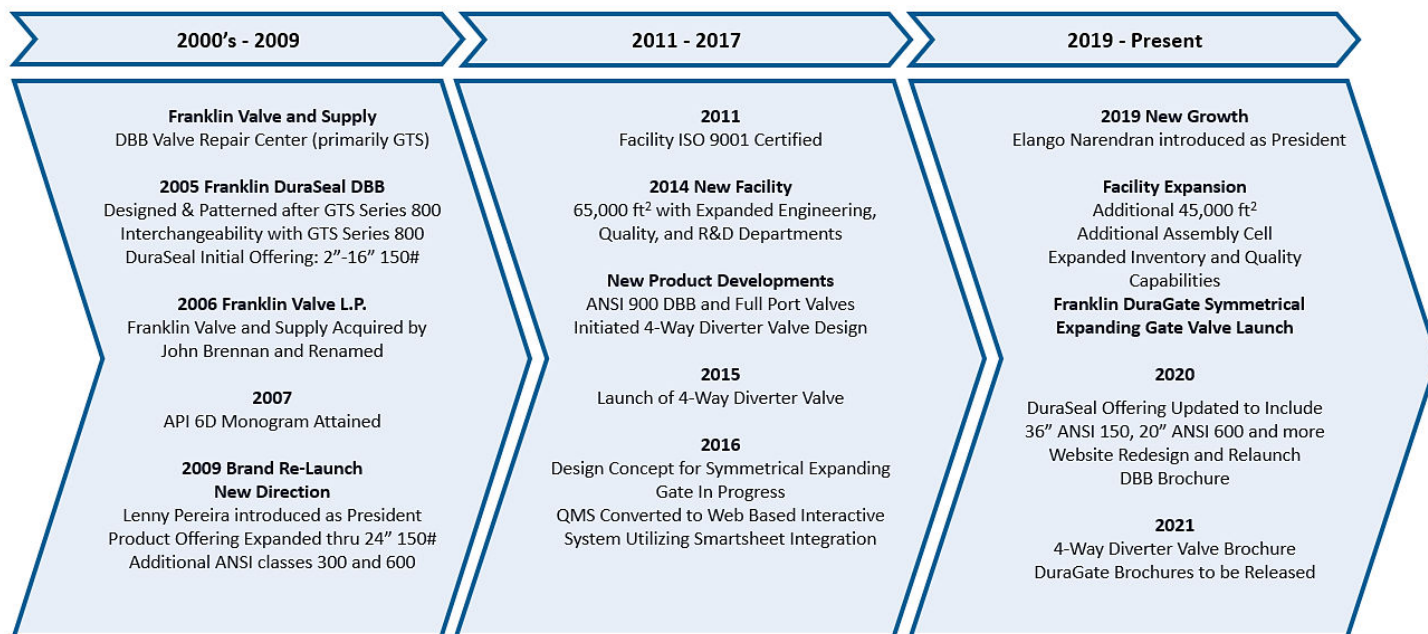

# How the DuraSeal™ 4-Way Diverter Valve Works

## Operation

The Franklin DuraSeal™ 4-Way Diverter Valve is a resilient seated, non-lubricated plug type valve which utilizes a mechanical action to perform diverting functions.

When diverting the flow, turn or actuate the operator clockwise or counterclockwise dependent on desired flow path, the plug will raise, retracting the seating slips through their tapered dovetail connections.

Once the seals are fully retracted, the plug and slips perform a 90° rotation, free of any seal surface abrasion.

Upon completing the 90° rotation, the plug is driven down between the tapered surfaces of the slips, causing expansion of the seals into the sealing surface for a positive seal.

Once seated the pressure gauge will indicate reduced pressure, proving the seal.

SEATED IN L/R OPEN – CW POSITION

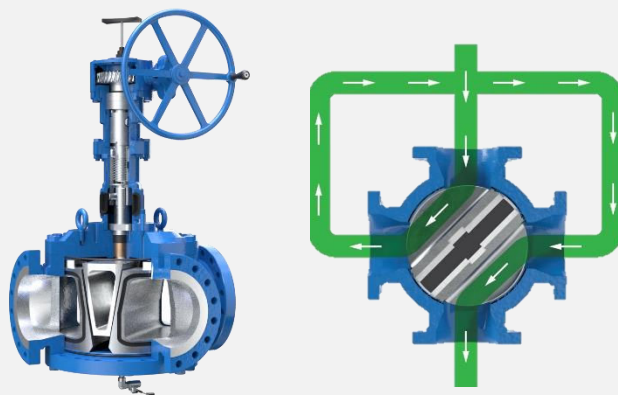

NEUTRAL FULLY UNSEATED – MID TRAVEL

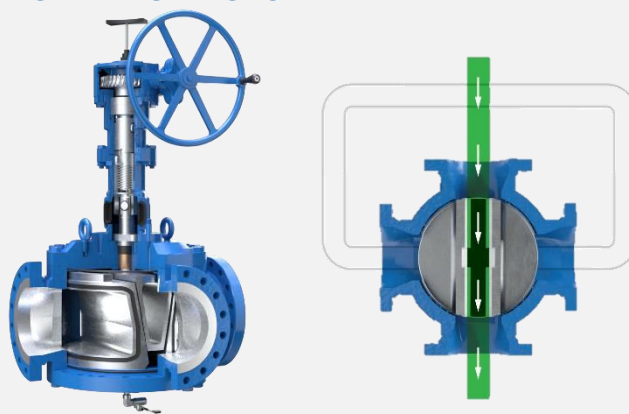

SEATED R/L CLOSE – CCW POSITION

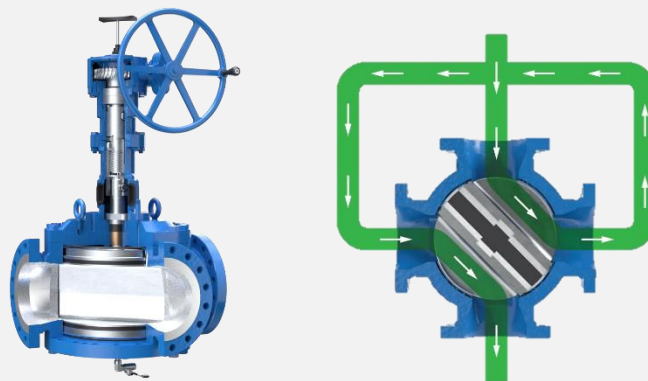

# Features and Benefits

## In-line Maintenance

The Franklin DuraSeal™ 4-Way Diverter Valve offers in-line maintenance to reduce operating costs and downtime. Slips are designed to be mounted to dovetail connections on the Plug allowing for removal from either the top or bottom of the valve without removing the valve from the line and without influencing the Actuator. This will allow for the 4-Way Diverter Valve to be installed upside down for easier access to the actuator and slips.

## Reliable Double Protection Mechanical Seal

The Franklin DuraSeal™ 4-Way Diverter Valve uses a pressure gauge DTR System to prove positive sealing for metering accuracy. During rotation of the plug there is no abrasion or wear between the sealing surfaces. The mechanical retraction and compression ensure a no leak stream separation and a longer seal life. Seals are made of highly resilient elastomers that are bonded to the Slips. The DuraSeal™ 4-Way Diverter Valve does not require sealant under any circumstances to seal.

## Fast Low Torque Operation

Manual and motorized operation can be possible with the use of an electric actuator. With lower cycling torques, smaller and less expensive actuators can be used.

## Quality Manufacturing

The Franklin 4-Way Diverter Valve is designed, inspected, assembled and tested in Houston, TX in an ISO 9001 certified and API Q1 compliant facility.

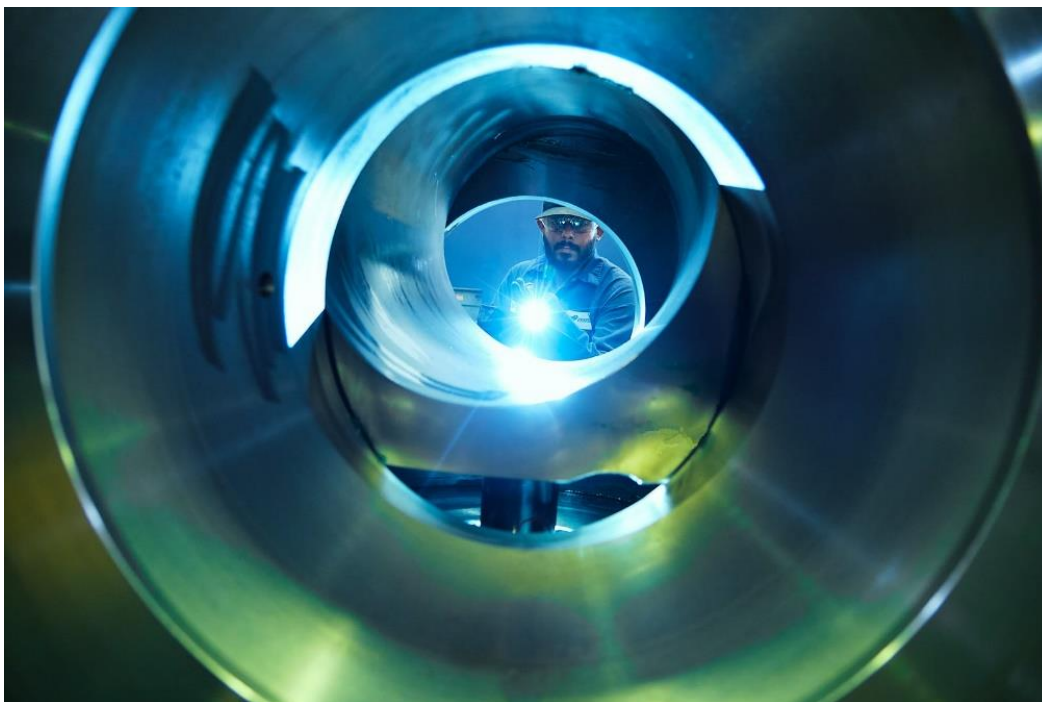

# Applications

- Bi-Directional Meter Prover
- Multi-Product Manifolds
- Metering Systems
- Custody Transfer Units
- Terminals
- Tank Farms (Oil Depots)
- Aviation Fueling Systems
- Fuel Loading Systems
- Hydrocarbon Services



# DuraSeal™ 4-Way Diverter Valve Internal View

Easily automated with choice of electric actuators. DuraSeal™ 4-Way Diverter Valve is available in wide range of elastomer materials.

## Applications

With bubble-tight, sealing the DuraSeal™ 4-Way is an excellent choice for meter proving applications where accuracy is necessary.

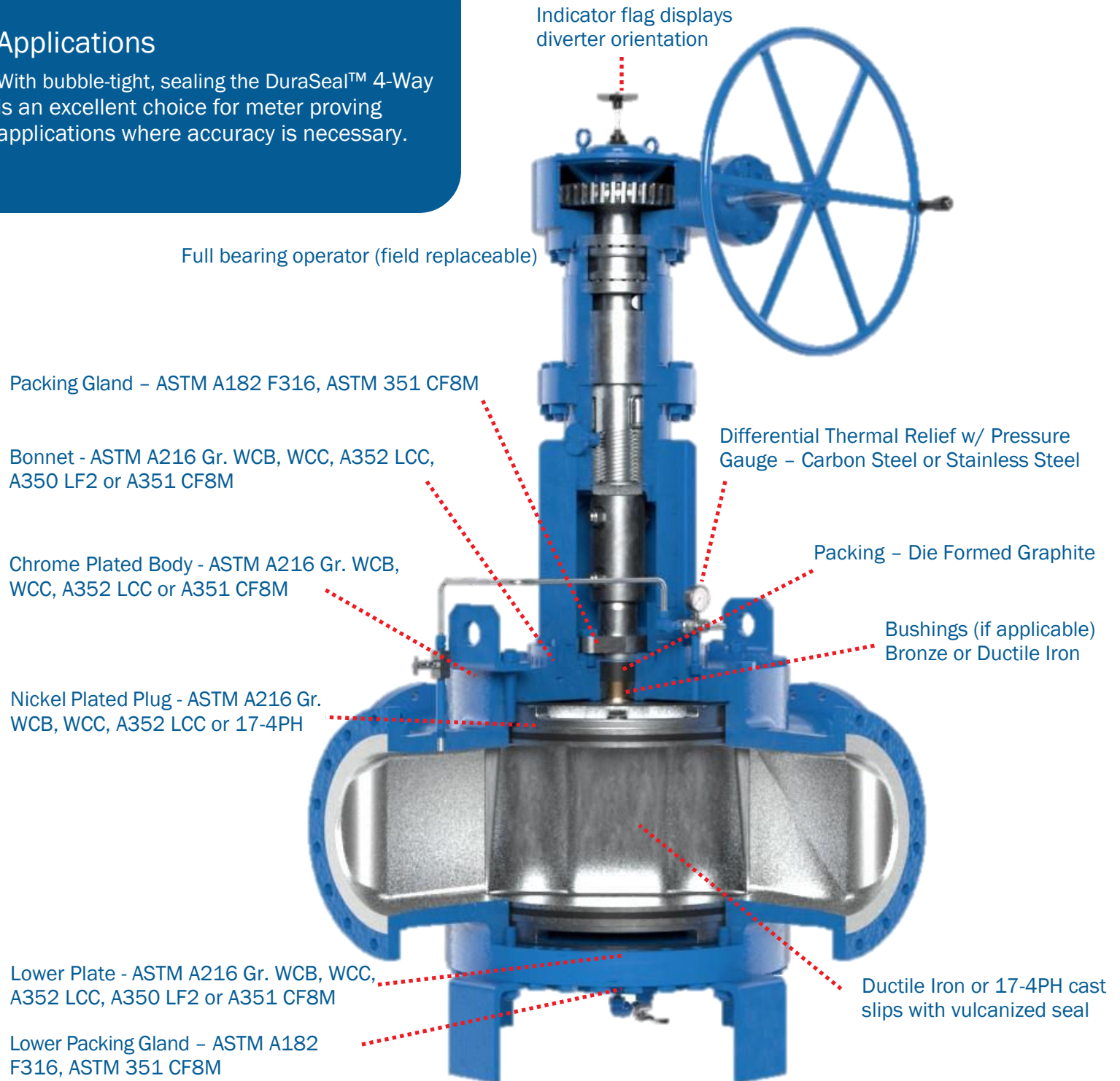

Franklin Valve reserves the right to change trim codes w/o prior notification



# Standard Materials of Construction

SERIES	Q411 ANSI 150	Q431 ANSI 300	Q461 ANSI 600
BODY (1)(2)	CAST CARBON STEEL ASTM A216 WCB w/ CHROME or ENP PLATED BORE	CAST CARBON STEEL ASTM A216 WCB w/ CHROME or ENP PLATED BORE	CAST CARBON STEEL ASTM A216 WCB w/ CHROME or ENP PLATED BORE
BONNET/LOWER PLATE (2)	CARBON STEEL ASTM A216 WCB or ASTM A350 LF2	CARBON STEEL ASTM A216 WCB or ASTM A350 LF2	CARBON STEEL ASTM A216 WCB or ASTM A350 LF2
PLUG/STEM (2)	ASTM A216 WCB, ASTM A350 LF2 w/ ELECTROLESS NICKEL PLATING	ASTM A216 WCB, ASTM A350 LF2 w/ ELECTROLESS NICKEL PLATING	ASTM A216 WCB, ASTM A350 LF2 w/ ELECTROLESS NICKEL PLATING
SLIPS (3)	DUCTILE IRON ASTM A536 GR. 60-40-18	DUCTILE IRON ASTM A536 GR. 60-40-18	DUCTILE IRON ASTM A536 GR. 60-40-18
GLAND	ASTM A182, ASTM A276 F316 or ASTM A357 CF8M	ASTM A182, ASTM A276 F316 or ASTM A357 CF8M	ASTM A182, ASTM A276 F316 or ASTM A357 CF8M
GLAND PACKING	GRAPHITE	GRAPHITE	GRAPHITE
BODY FIRE SEALS	STEEL or GRAPHITE	STEEL or GRAPHITE	STEEL or GRAPHITE
O-RINGS & SLIP SEALS (4)	VITON* GF	VITON* GF	VITON* GF
FASTENERS (5)	ASTM A193 GR. B7 / 2H	ASTM A193 GR. B7 / 2H	ASTM A193 GR. B7 / 2H

Note: All Materials subject to change without notice.

- (1) ENP Bore available. (2) In Accordance with NACE MRO175 Latest Edition. (3) Manganese Phosphate Coating available.  
 (4) See Additional Options Below. (5) NACE Specification Available.

Proper seal selection requires a number of considerations such as media, pressure class, differential pressure, low temperature, high temperature, seal type, etc. To that end we have included a selection of slip seal materials and a brief list of considerations:

Fluoro Elastomers Slip Seal Materials (FKM)		
FR	Fiber Reinforced	Optional HIDP, can be added to all Elastomer options upon request.
VGF	Viton* GF	Viton* with Enhanced Chem. Resistance, Our Standard Material
VGF9	Viton* 90 Durometer GF	HIDP Viton* GF
VGFLT	Viton* GFLT	Low Temp Viton* GF
VGFLT9	Viton* 90 Durometer GFLT	HIDP Low Temp Viton* GF
VE	Viton* ETP (Extreme)	Viton* with Chem. Resistance rivaling FFKM
VE9	Viton* 90 Durometer ETP	HIDP Viton* with Chem. Resistance rivaling FFKM
Perfluoro Elastomers Slip Seal Materials (FFKM)		
KRZ	Kalrez*	Kalrez* with High Chem. Resistance
KRZ9	Kalrez* 90 Durometer	HIDP Kalrez*

All specifications and materials are subject to change without notice. Alternate seal materials may be provided upon request.  
 \*Generic equivalents provided.

# Preferred Mounting Position

## 1.0 SCOPE OF INSTRUCTION

- 1.1. This information is provided for support of the DuraSeal™ 4-Way Diverter Valve in maintaining the maximum life and function of the valve.
- 1.2. The contained information is subject to change without notice.
- 1.3. This document provides information for typical installations. In the event of unique situations, please contact your representative or the factory.

## 2.0 DEFINITIONS

- 2.1. **DTR** - Differential Thermal Relief, provides the cavity relief functions of API 6D.

## 3.0 CONSIDERATIONS

- 3.1. Positioning of valve to provide operational access in installation. This is of particular concern for manually operated valves in pipe racks.
- 3.2. Positioning of the DTR to provide proper function. The conduit in which the DTR terminals should be installed to the inlet pipe of the prover.
- 3.3. Positioning of bleeds and drains to provide adequate operation. On valves which require complete draining, ensure that drains are positioned to provide complete draining.
- 3.4. Positioning for reducing damage due to solids contained in fluids. With solids in the fluids, it is preferable to have regular draining of the body cavity to reduce accumulation and reduction of performance. It is also preferable to have the DTR to the upper side so that solids do not damage the DTR checks or valves.

## 4.0 PREFERRED MOUNTING POSITIONS

- 4.1. Positioning of the stem facing up in the vertical position is preferable, in all instances.
- 4.2. 400 Series: 12" or smaller 150 & 300 class and 10" or smaller 600 class may be oriented with a horizontal stem position.

Q400 SERIES ANSI 150, 300, 600 – WORM GEAR OPERATED

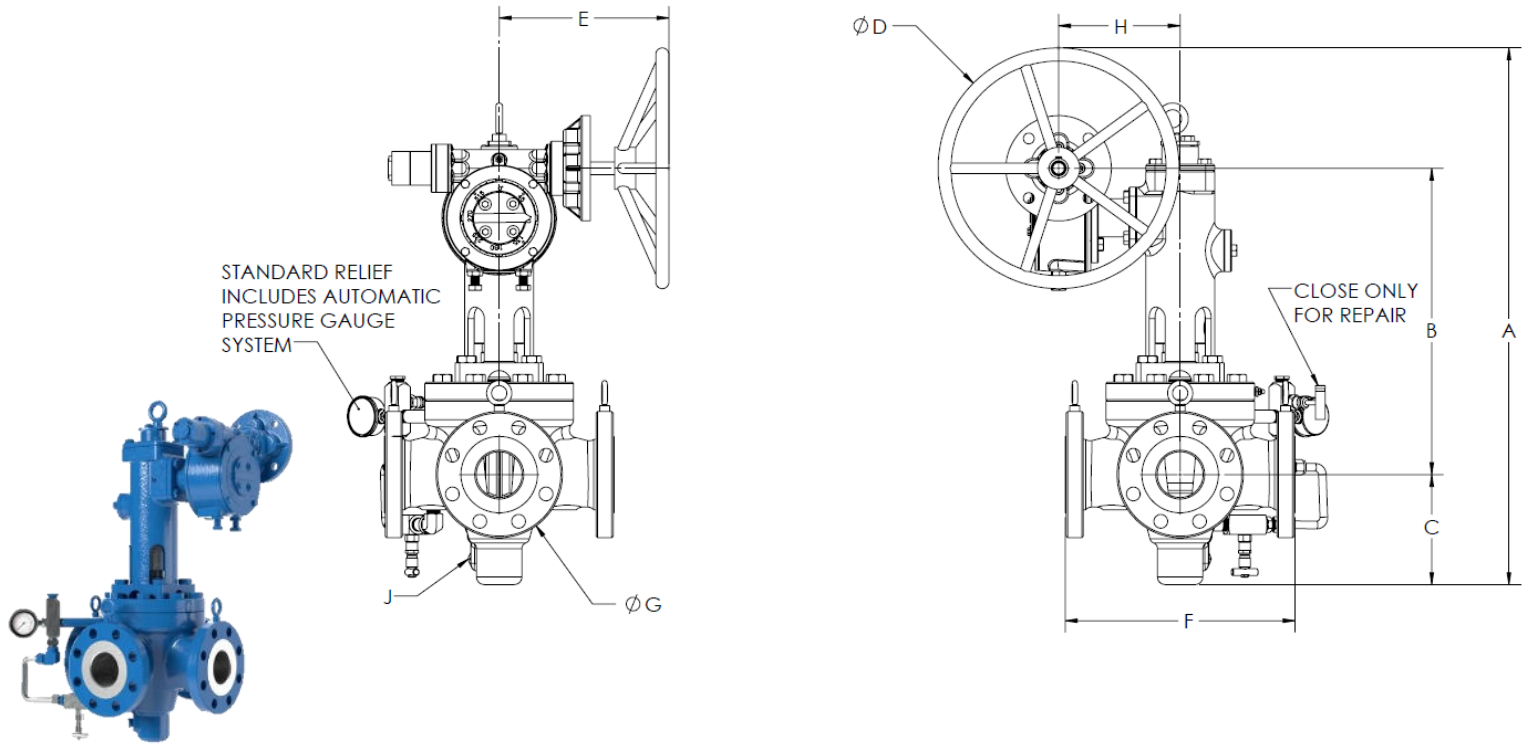

ANSI	SIZE	MODEL	OPER	GEAR	A	B	C	D	E	F	G	H	J	WEIGHT (1)	(2)	(3)	(4)
150	4	Q411	001	QD-92-008	36	21	8	16	11	20	9	7 9/10	15/16	347	NONE	1/2" NPT	1/2" NPT
300	2	Q431	001	QD-92-008	35	20	7	16	15	14	6 ½	7 9/10	7/8	256	NONE	1/2" NPT	1/2" NPT
	3	Q431	001	QD-92-008	35	20	7	16	15	15	8 3/10	7 9/10	1 1/8	292	NONE	1/2" NPT	1/2" NPT
	4	Q431	001	QD-92-008	36	21	8	16	15	20	10	7 9/10	1 1/4	388	NONE	1/2" NPT	1/2" NPT
600	2	Q461	001	QD-92-008	35	20	7	16	15	14 ½	6 ½	7 9/10	1 1/10	256	NONE	1/2" NPT	1/2" NPT
	3	Q461	001	QD-92-008	35	20	7	16	15	15 4/5	8 3/10	7 9/10	1 3/10	292	NONE	1/2" NPT	1/2" NPT

- (1) Approximate Weights (lbs).
- (2) Number and size tapped holes.
- (3) Tapped bleeder hole.
- (4) Bottom plate drain hole.

- (5) Contact factory for size requirements not listed.
- (6) Dimensions are not certified. Contact factory for certified drawings.

- (8) Consult factory for additional sizes.
- (9) Dimensions "F" & "G" are nominal. All others are rounded off to the nearest half-inch.

# Q400 SERIES ANSI 150, 300, 600 – GEAR OPERATED

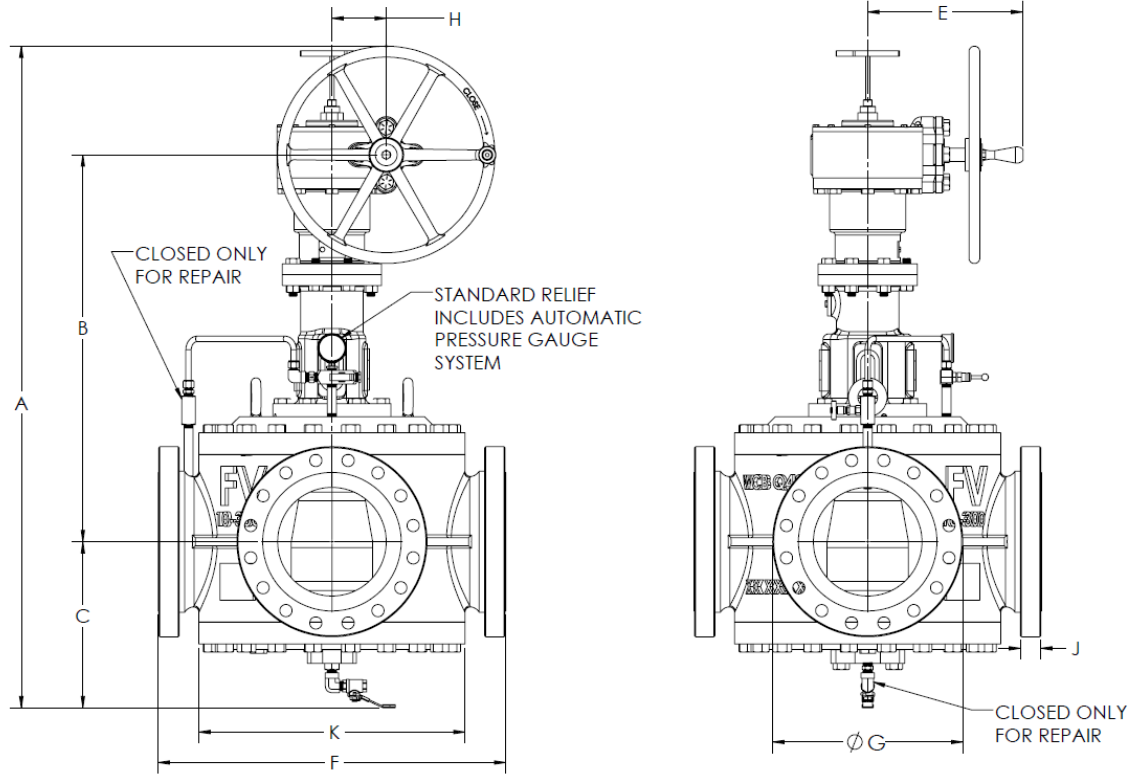

ANSI	SIZE	MODEL	OPER	A	B	C	D	E	F	G	H	J	K	WEIGHT (1)	(2)	(3)	(4)
150	12	Q411	502	66	37	18	20	14	44	19	5	1 1/5	24 1/2	3190	NONE	1/2" NPT	1/2" NPT
	16	Q411	702	101	61	24	32	23	60	23 1/2	9	1 1/2	34 1/4	7920	NONE	1/2" NPT	1/2" NPT
300	6	Q431	502	57	33	14	20	14	24	12 1/2	5	1 1/2	16 3/4	1300	NONE	1/2" NPT	1/2" NPT
	8	Q431	502	58	35	13	20	14	28	15	5	1 2/3	21 1/4	1800	NONE	1/2" NPT	1/2" NPT
	10	Q431	502	61	36	15	20	14	32	17 1/2	5	1 7/8	24 1/2	2700	NONE	1/2" NPT	1/2" NPT
	12	Q431	502	66	37	18	20	14	44	20 1/2	5	1 15/16	24 1/2	3390	NONE	1/2" NPT	1/2" NPT
	16	Q431	702	101	61	24	32	23	60	25 1/2	9	2 1/4	34 1/4	8420	NONE	1/2" NPT	1/2" NPT
600	4	Q461	402	48	26	12	20	12	20 7/8	10 3/4	4	1 5/8	14 1/4	750	NONE	1/2" NPT	1/2" NPT
	6	Q461	502	57	33	14	20	14	25 3/8	14	5	2	16 3/4	1400	NONE	1/2" NPT	1/2" NPT
	8	Q461	502	58	35	13	20	14	29 1/2	16 1/2	5	2 1/4	21 1/4	2010	NONE	1/2" NPT	1/2" NPT
	10	Q461	502	62	36	16	20	14	33 5/8	20	5	2 1/2	24 1/2	2980	NONE	1/2" NPT	1/2" NPT
	12	Q461	602	85	45	22	32	23	48	22	9	2 5/8	36 1/4	8735	NONE	1/2" NPT	1/2" NPT

- (1) Approximate Weights (lbs).
- (2) Number and size tapped holes.
- (3) Tapped bleeder hole.
- (4) Bottom plate drain hole.

- (5) Contact factory for size requirements not listed.
- (6) Dimensions are not certified. Contact factory for certified drawings.

- (8) Consult factory for additional sizes.
- (9) Dimensions "F" & "G" are nominal. All others are rounded off to the nearest half-inch.

Q400 SERIES ANSI 150, 300, 600

VALVE	OPERATOR	TORQUE (FT -LBS)	TORQUE (KG-M)	TURNS (+/-10%)	SEAT CW	QUARTER TURN	SEAT CCW	MIN. QUARTER TURN TIME (sec)	Cv	Kv
2" 300# Q431	001	57	7.9	16	4.75	6.5	4.75	0.13	300	68
2" 600# Q461	001	113	15.6	16	4.75	6.5	4.75	0.13	300	68
3" 300# Q431	001	57	7.9	16	4.75	6.5	4.75	0.13	300	68
3" 600# Q461	001	113	15.6	16	4.75	6.5	4.75	0.13	300	68
4" 150# Q411	001	37	5.1	16	4.75	6.5	4.75	0.25	600	136
4" 300# Q431	001	96	13.3	16	4.75	6.5	4.75	0.25	600	136
4" 600# Q461	402 <sup>(1)</sup>	100	13.8	13	5.25	2.5	5.25	0.25	600	136
6" 300# Q431	502 <sup>(1)</sup>	60	8.3	14.5	6.70	3.3	4.50	0.38	1200	273
6" 600# Q461	502 <sup>(1)</sup>	60	8.3	14.5	6.70	3.3	4.50	0.38	1200	273
8" 300# Q431	502 <sup>(1)</sup>	100	13.8	20	10.00	3.3	6.70	0.75	2100	477
8" 600# Q461	502 <sup>(1)</sup>	100	13.8	20	10.00	3.3	6.70	0.75	2100	477
10" 300# Q431	502 <sup>(1)</sup>	160	22.1	23	11.85	3.3	7.85	1.50	3900	886
10" 600# Q461	502 <sup>(1)</sup>	160	22.1	23	11.85	3.3	7.85	1.50	3900	886
12" 150# Q411	502 <sup>(1)</sup>	190	26.3	22	10.75	3.3	8.00	1.50	4300	977
12" 300# Q431	502 <sup>(1)</sup>	190	26.3	22	10.75	3.3	8.00	1.50	4300	977
12" 600# Q461	602 <sup>(1)</sup>	200	27.7	40	20.85	5.25	13.90	1.75	5300	1204
16" 150# Q411	702 <sup>(1)</sup>	240	33.2	38	19.90	5.25	12.80	4.50	7300	1658
16" 300# Q431	702 <sup>(1)</sup>	240	33.2	38	19.90	5.25	12.80	4.50	7300	1658

**Cv** US gallons per minute of flow with 60 degrees F water at 1 PSI pressure drop in the fully open position

**Kv** is cubic meters Per hours of flow with 16 degrees C water at 1 Bar pressure drop in the fully open position

**NOTES:**

- 1) 4-Way Gear Operators are not self-locking and therefor require the utilization of self-locking actuation.
- 2) All values subject to change, reference PUB-Q05-EN for up-to-date values.

## GEAR OPERATOR MOUNTING

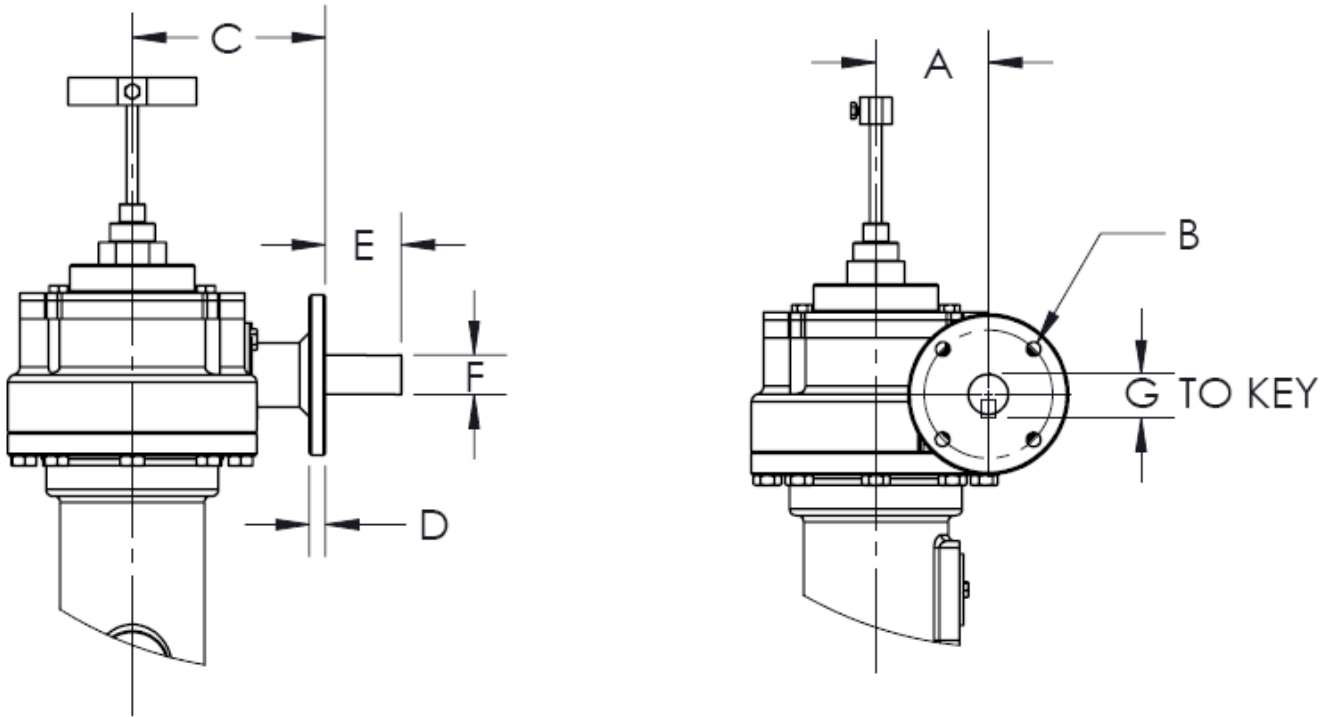

Model	A	ADAPTER	B-BOLT PATTERN	C	D	E	F	G
001	7.94	N/A	FA14: 4X Ø0.710 ON 5.5 BCD	5.9	0.51	2.8	Ø0.830/0.825 W/KEYWAY 0.236 x 2.36	0.926/0.936
402	3.50	29-1000	FA10: 4X Ø0.440 ON 4.0 BCD	6.0	0.50	2.4	1.250/1.245 W/KEYWAY 0.313 x 1.12	1.418/1.441
		29-2000	FA14: 4X Ø0.688 ON 5.5 BCD	6.0	0.63	2.4		
		29-2002	FA16: 4X Ø0.800 ON 6.5 BCD	6.0	0.63	2.4		
502	5.00	29-3000	FA10: 4X Ø0.400 ON 4.0 BCD	7.6	0.50	2.4		
		29-501	FA14: 4X Ø0.688 ON 5.5 BCD	8.0	1.05	2.4		
		29-2002	FA16: 4X Ø0.800 ON 6.5 BCD	8.0	1.05	2.4		
		29-501-FA25	FA25: 8X Ø0.688 ON 10.0 BCD	8.0	1.05	2.4		
602	9.00	29-601-FA16	FA16: 4X Ø0.812 ON 6.5 BCD	14.0	0.63	2.2	1.627/1.622 W/KEYWAY 0.313 x 2.12	1.777/1.787
		29-601-FA25	FA25: 8X Ø0.688 ON 10.0 BCD	14.0	1.00	2.2		
702	9.00	29-601-FA16	FA16: 4X Ø0.812 ON 6.5 BCD	14.0	1.00	2.2		
		29-601-FA25	FA25: 8X Ø0.688 ON 10.0 BCD	14.0	1.00	2.2		

- SHOWN WITH STANDARD SHAFTS. CONTACT FACTORY FOR NONSTANDARD CONFIGURATIONS.
- WGA MAY BE FIELD REPOSITIONED IN 90 INCREMENTS ON STEM CL.
- VALUES SUBJECT TO CHANGE, REFERENCE QS-0014 FOR MOST UP TO DATE VALUES.

## STANDARD DIFFERENTIAL THERMAL RELIEF (DTR)

**BODY BLEED VALVE** is only for the purposes of manually venting the body cavity. When not being used for bleeding, the body bleed valve should be closed and the outlet should be plugged.

**UPSTREAM ISOLATION VALVE** must be left open for cavity relief to function. It should only be closed for maintenance and leakage management in the event of damage. This flange should be installed as the Inlet or outlet flange.

**PRESSURE GAUGE** is used to identify seal integrity in service. During seating, the expanding slips create an increase in volume between seals, causing a drop in valve cavity pressure with respect to line pressure. Leakage past slip seals will increase this cavity pressure back to line pressure.

**IN-LINE CHECK VALVE** ensures trapped cavity fluid does not exceed line pressure due to thermal expansion.

Directionality Characteristics of Valve Are Shown Below

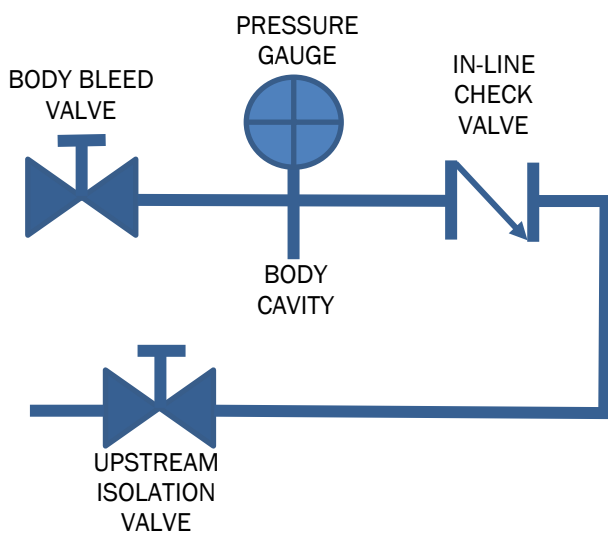

 500 Northpark Central Dr. Suite 100 Houston, Texas 77073

 713.812.7100

 sales@franklinvalve.com

 www.franklinvalve.com

 www.linkedin.com/franklin-valve-lp

