

# GWC Italia

Proven technology  
for individual valve solutions  
worldwide



## DUAL PLATE CHECK VALVES

WC-1002

The logo for GWC Italia, featuring the letters "GWC" in a bold, blue, sans-serif font with a registered trademark symbol (®) to the upper right.



**TABLE OF CONTENTS**

<b>GWC Italia Worldwide Network</b>	<b>4</b>
<b>Company Overview, Certifications &amp; Standards</b>	<b>5</b>
<b>Dual Plate Check Valve Standard Features</b>	<b>6</b>
<b>Ordering Guide</b>	<b>7</b>

**WAFER TYPE CHECK VALVE**

Class 150	8
Class 300	9
Class 600	9
Class 900	10
Class 1500	10
Class 2500	10
API 2000	11
API 3000	11
API 5000	11

**SOLID LUG CHECK VALVE**

Class 150	12
Class 300	13
Class 600	13
Class 900	13
Class 1500	14
Class 2500	14

**DOUBLE FLANGE CHECK VALVE**

Class 150	15
Class 300	16
Class 600	16
Class 900	16

<b>Pressure–Temperature Ratings</b>	<b>17</b>
-------------------------------------	-----------

# GWC Italia

## Worldwide Network

**ITALY GROUP  
HEADQUARTERS,  
PRODUCTION & SALES**

GWC Italia, SpA  
Via A. Grandi, 5  
20056 Trezzo Sull'Adda  
Milano, Italy  
Phone: 39-02-86882941  
Fax: 39-02-86882942  
Email: sales@gwcitalia.com



California

Texas

Italia

U.A.E.

China



**USA HEADQUARTERS  
PRODUCTION & SALES**

GWC USA, Inc.  
8502 Crippen Street  
Bakersfield, CA. 93313  
ph: +1-661.834.1775  
fax: +1-661.834.2072  
Email: sales@gwcitalia-usa.com



**SALES**

GWC USA, Inc  
24624 Interstate 45 N.  
Spring, Texas 77386  
Toll Free: +1.877.768.3760  
ph: +1.281.719-1986  
Email: sales@gwcitalia-usa.com



**SALES**

GWC Valve & Controls DMCC,  
Dubai  
1506, Platinum Tower  
I-Cluster,  
Jumeirah Lake Towers  
Dubai UAE  
ph: +971-44.539.358  
Email: sales@gwcitalia.com



**PRODUCTION & SALES**

GWC Valve Manufacturing  
(Shanghai) Co., Ltd.  
No 3600 Jihe Rd,  
Huaxin Town,  
Qingpu, Shanghai 201708,  
China  
ph: +86-21.597.987.99  
fax: +86-21.597.987.90  
Email: sales@gwcitalia.com

**GWC Italia SpA** with its Headquarters in Milan, Italy designs, manufacturers and markets valves with one of the most extensive lines you will find in the Industry today. GWC Italia SpA which is founded by an Italian Group & USA Entrepreneurial Management team, has become the Parent Company of the long standing GWC Worldwide Companies. This Italian & USA team has a history of building and managing successful valve manufacturing companies over the past 40 years. The valves manufactured in Italy will be complementary to the existing GWC line consisting of diversified flow control packages in a variety of alloys, trims, configurations, sizes and pressure classes, from general to severe applications. GWC Valves are used in major applications for Upstream, Downstream & Transportation Segments of the Oil & Gas Industry, E&P, Petrochemical, Chemical, Mining/Minerals, Power, Marine and Industrial markets.

**GWC Italia SpA extensive line of valve and flow control products include but not limited to:**

- Trunnion Mounted Ball Valves (soft & metal seated)
  - Split Body
  - Top Entry
  - Welded Body
  - Subsea
  - Cryogenic & High Temperature
  - Two Balls One Body DBBV
- Pipeline Gate and Check Valves
- Floating Ball Valves
- Gate, Globe and Check Valves including Cast & Forged
- Butterfly Valves including Triple Offset, High Performance and Resilient Seated
- Dual Plate Check Valves
- Needle and Gauge Valves
- Wellhead Gate Valves

GWC Italia Spa products are designed, engineered and manufactured to exceed its customer's stringent process requirements including API 6D, API 6A, API 6DSS, API 600, API 602, API 608, ISO 9001, PED, ATEX, SIL 3 and TA – Luft.



**Proven technology  
for individual valve solutions  
worldwide**

## CERTIFICATIONS & STANDARDS

### American Standards

#### American Petroleum Institute

API-6D	Specification for Pipeline Valves
API-6D SS	Specification for Subsea Pipeline Valves
API-6A	Specification for Wellhead and Christmas Tree Equipment
API-6FA	Specification for Fire Test for Valves
API-594	Check Valves: Wafer, Wafer-Lug, and Double Flanged Type
API-598	Valve Inspection and Testing
API-600	Bolted Bonnet Steel Gate Valves for Petroleum and Natural Gas Industries
API-602	Compact Steel Gate Valves- Flanged, Threaded, Welding and Extended-Body Ends
API-607	Fire Test for Soft-Seated Quarter-Turn Valves
API-608	Metal Ball Valves - Flanged, Threaded, and Welding End
API-609	Butterfly Valves: Double Flanged, Lug and Wafer-Type
API-Q1	Specification for Quality Programs for the Petroleum, Petrochemical & Natural Gas

#### American Society of Mechanical Engineers

ASME-B1.20.1	Pipe Threads, General Purpose (inch)
ASME-B16.11	Forged Fittings, Socket-Welding and Threaded
ASME-B16.10	Face to Face and End to End Dimensions of Valves
ASME-B16.5	Pipe Flanges and Flanged Fittings NPS 1/2 ~ NPS 24
ASME-B16.47	Large Diameter Steel Flanges NPS 26 ~ NPS 60
ASME-B16.25	Buttwelding Ends
ASME-B16.34	Valves - Flanged, Threaded and Welding End

### International Standards

ISO 9001:2008	Quality Management Systems
ISO 14001	Environmental Management
OHSAS 18001:2007	Occupational Health and Safety Management System
ISO/TS 29001	Petroleum, Petrochemical and Natural Gas Industries - Sector Specific Quality Management Systems
CE/PED	Pressure Equipment Directive
CU-TR	Technical Reglament Conformity Certificate TRCU
CRN	Canadian Registration Number
Z245.15.96	Pipeline Steel Valves
ATEX	European for explosive atmosphere
SIL3	Measurement of performance required for safety instrument function

**STANDARD FEATURES**

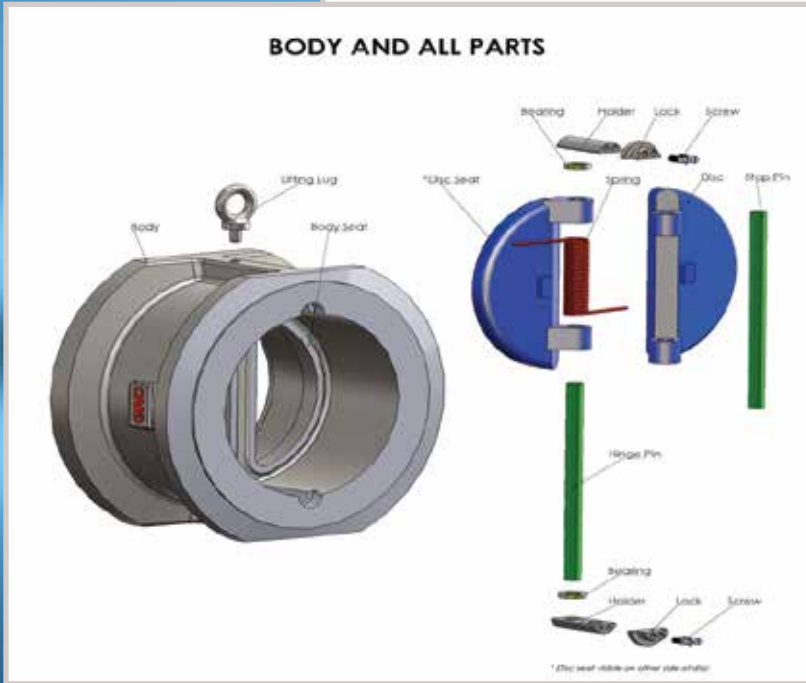

**Industry Standards:**

- ASME B16.1, B16.5, B16.24, B16.34, B16.47 and B31.1
- API 594 and 598
- MSS-SP-25, MSS-SP-55
- API 6A and 6D (as applicable)
- MSS-SP-61 (standard for the resilient seated, metal seated when required)
- NACE MR-01-75 (Latest Edition, when required)

**Technical Data:**

Size range : 2” thru 60”  
 Pressure Classes : ASME 125 thru 2500  
 : API 2000 thru 5000  
 Temperature Range : -46°F to 1100°F

**Design Features:**

- Retainer less design eliminates fugitive Emissions. Is firesafe by design.
- A more compact Light weight design Is 80 to 90% lighter than conventional full-body swing check valves.
- Simplifies piping for an easier, less costly installation. Optimum space utilization for simplified piping.
- Spring-loaded, dual plate design has Very low cracking pressure.
- Discs open 85° to ensure a low pressure drop.
- Positive sealing under most operating conditions. The valve closes before the flow reverses at zero velocity.
- With the spring assisted closing, water Hammer is all but eliminated.
- By design the valve is inherently non-slamming. This is due to the plates closing before the media flow reverses.
- The Wafer check valve can be installed in the horizontal and vertical up positions.  
 For vertical down installations please contact GWC.

NO.	PART NAME	WCB / A105 Trim #8	WCB / A105 Trim #1	LCC / LF2 Trim #10	LCC / LF2 Trim #12	CF8 / F304 Trim #2	CF8 / F304 Trim #2S	CF8M / F316 Trim #10	CF8M / F316 Trim #12
1	BODY	WCB/A105	WCB/A105	LCC/LF2	LCC/LF2	CF8/304	CF8/304	CF8M/316	CF8M/316
2	BODY SEAT	STL	13Cr	SS316	STL	as same as body	STL	as same as body	STL
3	DISC	CF8/CA15	CF8/CA15	CF8M	CF8M	CF8	CF8	CF8M	CF8M
4	DISC SEAT	same as disc							
5	HOLDER	CF8/CA15	CF8/CA15	CF8M	CF8M	CF8	CF8	CF8M	CF8M
6	BEARING	SS410	SS410	SS316	SS316	SS304	SS304	SS316	SS316
7	SPRING	INCONEL X-750							
8	HINGE PIN	SS410	SS410	SS316	SS316	SS304	SS304	SS316	SS316
9	STOP PIN	SS410	SS410	SS316	SS316	SS304	SS304	SS316	SS316
10	LOCK	A105	A105	SS316	SS316	SS304	SS304	SS316	SS316
11	SCREW	SS304	SS304	SS316	SS316	SS304	SS304	SS316	SS316
12	LIFTING LUG	CARBON STEEL							

**ORDERING GUIDE**

**Example: 8" Figure #36600-A-10-E**

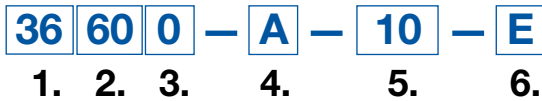

8" CLASS 600 DUAL PLATE CHECK, WAFER TYPE, RF, A216 WCB BODY, A351 CF8M DISC, 316SS FACED BODY SEAT, EPDM SEAT, INCONEL X-750 SPRING

**1. MODEL**

- |                                    |                              |
|------------------------------------|------------------------------|
| 36 - WAFER TYPE                    | 39 - FLANGED TYPE            |
| 37 - LUGGED TYPE THREADED          | 40 - SINGLE PLATE WAFER TYPE |
| 38 - LUGGED TYPE THRU-HOLE DRILLED |                              |

**2. RATING**

- |                  |                  |
|------------------|------------------|
| 12 - CLASS 125   | 250 - CLASS 2500 |
| 15 - CLASS 150   | 200 - API 2000   |
| 30 - CLASS 300   | 300 - API 3000   |
| 60 - CLASS 600   | 500 - API 500    |
| 90 - CLASS 900   |                  |
| 150 - CLASS 1500 |                  |

**3. END CONNECTION**

- |                |                              |
|----------------|------------------------------|
| 0 - RF FLANGED | 9 - RTJ FLANGED              |
| 6 - FF FLANGED | X - SPECIAL - PLEASE SPECIFY |

**4. BODY MATERIAL**

- |                  |                                |
|------------------|--------------------------------|
| A - WCB/ A105    | U - A890-6A                    |
| C - LCC/ LF2     | V - A126 CAST IRON             |
| M - CF8/ F304SS  | W - A395 DUCTILE IRON          |
| N - CF8M/ F316SS | X - B148 Gr. C95800 AL. BRONZE |
| R - CN7M         | O - SPECIAL - PLEASE SPECIFY   |
| S - A890-4A      |                                |
| T - A890-5A      |                                |

**5. TRIM**

- |                        |                            |
|------------------------|----------------------------|
| 1 WCB+13CR             | 9 CN7M                     |
| 8 WCB+1/2 STELLITE     | 11 CN7M+1/2 STELLITE       |
| 5 WCB+FULL STELLITE    | 21 A890-4A                 |
| 2 304SS                | 22 A890-5A                 |
| 2S 304SS+1/2 STELLITE  | 23 A890-6A                 |
| 15 304SS+FULL STELLITE | 24 B148                    |
| 10 316SS               | X SPECIAL - PLEASE SPECIFY |
| 12 316SS+1/2 STELLITE  |                            |
| 16 316SS+FULLSTELLITE  |                            |

**6. BODY SEAT**

- |            |               |
|------------|---------------|
| M - METAL  | V - VITON "B" |
| B - BUNA-N | H - HNBR      |
| E - EPDM   |               |

**7. SPECIAL REQUIREMENTS**

- |                  |                                 |
|------------------|---------------------------------|
| N - NACE MR01-75 | S - SUPPLY COMPLETE INFORMATION |
|------------------|---------------------------------|

**WAFER TYPE DUAL PLATE CHECK VALVE**

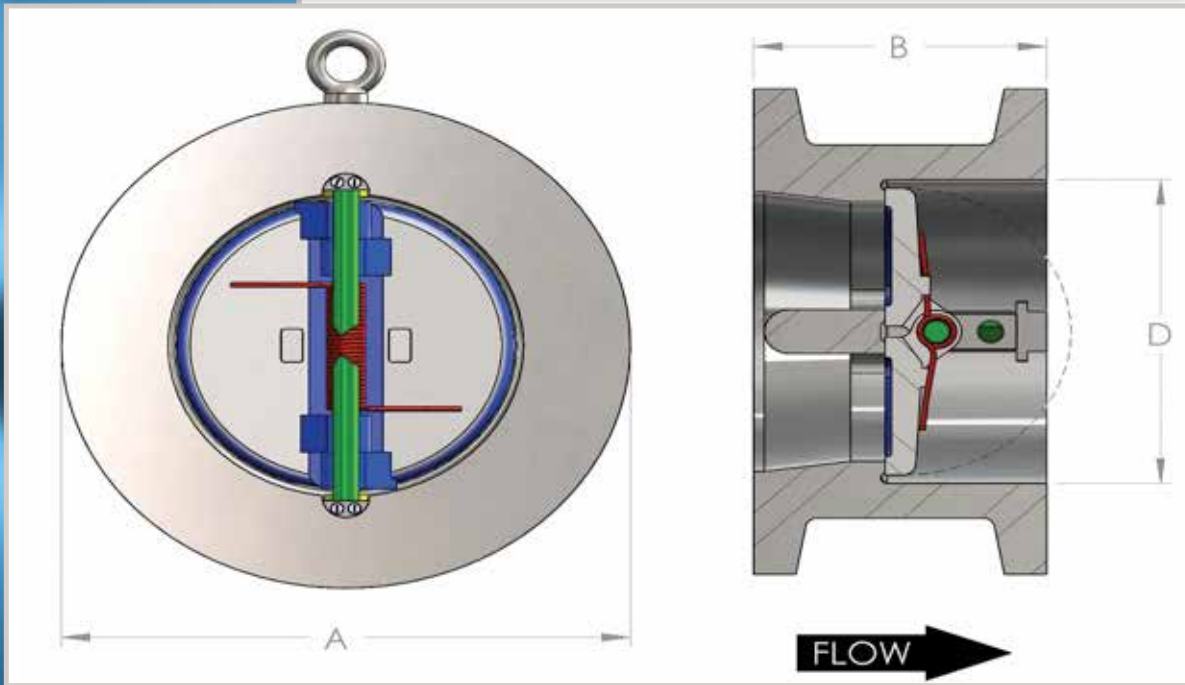

**Construction:** Dual plate check valves, Wafer type, Retainer less design, Spring loaded, Horizontal or Vertical positions.

**Dimensions**

Face to Face	ASME B16.10
End Flange	ASME B16.5*
Rating ASME	Class 150-2500

\*26" and larger are available with ASME B16.47 end flanges, either Series A or Series B (formerly MSS SP-44 and API 605.)

**MODEL 36150**

Dimensions & Weights - Wafer Type - ASME Class 150

SIZE		DIMENSIONS						WEIGHT		No.	STUD DETAILS			
NPS	DN	B		A		D		Lbs	Kgs		DIAMETER		STUD LENGTH (RF)	
		in	mm	in	mm	in	mm			in	mm	in	mm	
1-1/2"	40	2.36	60	3.35	85	1.65	42	3	1.5	4	1/2"	M12	5.12	130
2"	50	2.36	60	4.06	103	2.17	55	5	2.2	4	5/8"	M16	5.51	140
2-1/2"	65	2.64	67	4.8	122	2.68	68	7	3.1	4	5/8"	M16	5.91	150
3"	80	2.87	73	5.31	135	3.23	82	9	4.3	4	5/8"	M16	6.3	160
4"	100	2.87	73	6.81	173	4.25	108	14	6.3	8	5/8"	M16	6.69	170
5"	125	3.39	86	7.68	195	5.12	130	18	8.4	8	3/4"	M20	7.48	190
6"	150	3.86	98	8.7	221	6.5	165	28	12.6	8	3/4"	M20	8.07	205
8"	200	5	127	8.94	227	8.66	220	53	24	8	3/4"	M20	9.45	240
10"	250	5.75	146	13.27	337	10.63	270	88	40	12	7/8"	M24	10.63	270
12"	300	7.13	181	16.02	407	12.6	320	145	66	12	7/8"	M24	12.2	310
14"	350	7.24	184	17.64	448	13.78	350	183	83	12	1"	M27	12.8	325
16"	400	7.52	191	20.16	512	15.75	400	224	102	16	1"	M27	13.39	340
18"	450	7.99	203	21.54	547	17.24	438	273	124	16	1-1/8"	M30	14.37	365
20"	500	8.62	219	23.78	604	19.49	495	330	150	20	1-1/8"	M30	15.16	385
24"	600	8.74	222	28.15	715	23.43	595	447	203	20	1-1/4"	M33	15.94	405
28"	700	12.01	305	32.68	830	26.97	685	836	380	28	1-1/4"	M33	21.26	540
30"	750	12.01	305	34.65	880	28.94	735	909	413	28	1-1/4"	M33	21.65	550
32"	800	12.01	305	36.93	938	30.71	780	1276	580	28	1-1/2"	M39	22.44	570
36"	900	14.49	368	41.14	1045	34.45	875	1463	665	32	1-1/2"	M39	25.98	660
40"	1000	17.01	432	45.67	1160	38.39	975	1936	880	36	1-1/2"	M39	28.35	720
42"	1050	17.01	432	47.87	1216	40.16	1020	2196	998	36	1-1/2"	M39	29.13	740
48"	1200	20.63	524	54.33	1380	45.87	1165	3234	1470	44	1-1/2"	M39	33.46	850
54"	1350	22.36	568	60.87	1546	51.97	1320	4620	2100	44	1-3/4"	M45	37.01	940
60"	1500	24.76	629	67.24	1708	57.48	1460	6490	2950	52	1-3/4"	M45	40.16	1020



**WAFER TYPE DUAL PLATE CHECK VALVE**

**MODEL 36300**

Dimensions & Weights - Wafer Type - ASME Class 300

SIZE		DIMENSIONS						WEIGHT		STUD DETAILS					
NPS	DN	B		A		D		Lbs	Kgs	No.	DIAMETER		STUD LENGTH (RF)		
		in	mm	in	mm	in	mm				in	mm	in	mm	
1-1/2"	40	2.36	60	3.7	94	1.65	42	4	1.8	4	3/4"	M20	6.3	160	
2"	50	2.36	60	4.33	110	2.17	55	6	2.5	8	5/8"	M16	6.1	155	
2-1/2"	65	2.64	67	5.04	128	2.68	68	9	4	8	3/4"	M20	6.89	175	
3"	80	2.87	73	5.79	147	3.23	82	11	5	8	3/4"	M20	7.48	190	
4"	100	2.87	73	7.05	179	4.25	108	15	7	8	3/4"	M20	7.68	195	
5"	125	3.39	86	8.43	214	5.12	130	25	11.2	8	3/4"	M20	8.46	215	
6"	150	3.86	98	9.8	249	6.5	165	36	16.5	12	3/4"	M20	9.06	230	
8"	200	5	127	12.01	305	8.66	220	69	31.5	12	7/8"	M24	11.02	280	
10"	250	5.75	146	14.13	359	10.63	270	109	49.5	16	1"	M27	12.4	315	
12"	300	7.13	181	16.54	420	12.6	320	178	81	16	1-1/8"	M30	14.37	365	
14"	350	8.74	222	19.02	483	13.5	343	257	117	20	1-1/8"	M30	16.14	410	
16"	400	9.13	232	21.14	537	15.75	400	348	158	20	1-1/4"	M33	17.13	435	
18"	450	10.39	264	23.39	594	17.24	438	440	200	24	1-1/4"	M33	18.7	475	
20"	500	11.5	292	25.67	652	19.49	495	627	285	24	1-1/4"	M33	20.08	510	
24"	600	12.52	318	30.39	772	23.43	595	836	380	24	1-1/2"	M39	22.05	560	
28"	700	14.49	368	35.28	896	26.97	685	1289	586	28	1-5/8"	M42	25.98	660	
30"	750	14.49	368	37.4	950	28.94	735	1531	696	28	1-3/4"	M45	26.77	680	
32"	800	14.49	368	39.53	1004	30.71	780	2169	986	28	1-7/8"	M48	27.56	700	
36"	900	19.02	483	43.86	1114	34.45	875	2354	1070	32	2"	M51	33.07	840	
40"	1000	22.36	568	43.7	1110	38.39	975	2904	1320	32	1-5/8"	M42	36.22	920	
42"	1050	22.36	568	45.67	1160	40.16	1020	3300	1500	32	1-5/8"	M42	36.61	930	
48"	1200	24.76	629	51.97	1320	45.87	1165	4950	2250	32	1-7/8"	M48	40.55	1030	
54"	1350	25	635	58.58	1488	51.97	1320	7392	3360	28	2-1/4"	M57	43.7	1110	
60"	1500	27.6	701	64.57	1640	57.48	1460	9735	4425	32	2-1/4"	M57	46.85	1190	

**MODEL 36600 / 36609**

Dimensions & Weights - Wafer Type - ASME Class 600

SIZE		DIMENSIONS						WEIGHT		STUD DETAILS						
NPS	DN	B		A		D		Lbs	Kgs	No.	DIAMETER		STUD LENGTH (RF)		STUD LENGTH (RTJ)	
		in	mm	in	mm	in	mm				in	mm	in	mm	in	mm
2"	50	2.36	60	4.33	110	2.17	55	6	2.5	8	5/8"	M16	6.89	175	7.09	180
2-1/2"	65	2.64	67	5.04	128	2.68	68	9	4	8	3/4"	M20	7.68	195	7.87	200
3"	80	2.87	73	5.79	147	3.23	82	11	5	8	3/4"	M20	8.27	210	8.46	215
4"	100	3.11	79	7.52	191	4.25	108	20	9	8	7/8"	M24	9.25	235	9.45	240
5"	125	4.13	105	9.45	240	5.12	130	32	14.5	8	1"	M27	11.02	280	11.22	285
6"	150	5.35	136	10.39	264	6.5	165	59	27	12	1"	M27	12.6	320	12.8	325
8"	200	6.5	165	12.52	318	8.27	210	106	48	12	1-1/8"	M30	14.57	370	14.76	375
10"	250	8.39	213	15.67	398	10.04	255	206	93.5	16	1-1/4"	M33	17.32	440	17.52	445
12"	300	9.02	229	17.91	455	11.81	300	252	114.5	20	1-1/4"	M33	18.11	460	18.31	465
14"	350	10.75	273	19.29	490	13.19	335	411	187	20	1-3/8"	M36	20.47	520	20.67	525
16"	400	12.01	305	22.13	562	15.16	385	574	261	20	1-1/2"	M39	22.64	575	22.83	580
18"	450	14.25	362	24.02	610	17.13	435	803	365	20	1-5/8"	M42	25.59	650	25.79	655
20"	500	14.49	368	26.77	680	19.17	487	997	453	24	1-5/8"	M42	26.38	670	26.77	680
24"	600	17.24	438	30.94	786	23.03	585	1551	705	24	1-7/8"	M48	30.71	780	31.1	790
28"	700	19.88	505	35.91	912	26.97	685	2189	995	28	2"	M51	34.25	870	34.65	880
30"	750	19.88	505	38.11	968	28.94	735	2596	1180	28	2"	M51	34.65	880	35.04	890
32"	800	19.88	505	40.16	1020	30.71	780	3685	1675	28	2-1/4"	M57	35.43	900	35.83	910
36"	900	25	635	44.41	1128	34.45	875	4620	2100	28	2-1/2"	M64	41.34	1050	41.73	1060
40"	1000	27.6	701	45.36	1152	38.39	975	4939	2245	32	2-1/4"	M57	46.46	1180	46.85	1190
42"	1050	27.6	701	47.83	1215	40.16	1020	5610	2550	28	2-1/2"	M64	47.64	1210	48.03	1220
48"	1200	30.98	787	54.57	1386	45.87	1165	8426	3830	32	2-3/4"	M70	53.54	1360	53.94	1370

**WAFER TYPE DUAL PLATE CHECK VALVE**

**MODEL 36900 / 36909**

Dimensions & Weights - Wafer Type - ASME Class 900

SIZE		DIMENSIONS						WEIGHT		STUD DETAILS						
NPS	DN	B		A		D		Lbs	Kgs	No.	DIAMETER		STUD LENGTH (RF)		STUD LENGTH (RTJ)	
		in	mm	in	mm	in	mm				in	mm	in	mm	in	mm
2"	50	2.76	70	5.51	140	2.17	55	13	6	8	7/8"	M24	8.86	225	9.06	230
2-1/2"	65	3.27	83	6.38	162	2.68	68	17	7.5	8	1"	M27	9.84	250	10.04	255
3"	80	3.27	83	6.5	165	3.23	82	21	9.6	8	7/8"	M24	9.45	240	9.65	245
4"	100	4.02	102	8.03	204	4.25	108	37	17	8	1-1/8"	M30	11.22	285	11.42	290
5"	125	4.33	110	9.65	245	5.12	130	62	28	8	1-1/4"	M33	12.2	310	12.4	315
6"	150	6.26	159	11.26	286	6.3	160	90	41	12	1-1/8"	M30	14.37	365	14.57	370
8"	200	8.11	206	14.02	356	8.27	210	176	80	12	1-3/8"	M36	17.32	440	17.52	445
10"	250	9.49	241	17.01	432	10.04	255	297	135	16	1-3/8"	M36	19.29	490	19.49	495
12"	300	11.5	292	19.49	495	11.81	300	466	212	20	1-3/8"	M36	22.05	560	22.24	565
14"	350	14.02	356	20.47	520	12.8	325	737	335	20	1-1/2"	M39	25.39	645	25.79	655
16"	400	15.12	384	22.52	572	14.96	380	869	395	20	1-5/8"	M42	26.97	685	27.36	695
18"	450	17.76	451	25.04	636	16.73	425	1320	600	20	1-7/8"	M48	31.1	790	31.5	800
20"	500	17.76	451	27.4	696	18.7	475	1782	810	20	2"	M52	31.89	810	32.28	820
24"	600	19.49	495	32.87	835	22.44	570	2266	1030	20	2-1/2"	M64	37.2	945	37.6	955
28"	700	22.01	559	37.17	944	26.38	670	3190	1450	20	3"	M76	41.34	1050	41.73	1060
30"	750	22.01	559	39.69	1008	28.15	715	4004	1820	20	3"	M76	41.73	1060	42.13	1070
32"	800	22.01	559	42.13	1070	29.92	760	4620	2100	20	3-1/4"	M82	4.33	110	43.7	1110
36"	900	27.6	701	47.17	1198	33.86	860	7150	3250	20	3-1/2"	M88	50.39	1280	50.79	1290

**MODEL 361500 / 361509**

Dimensions & Weights - Wafer Type - ASME Class 1500

SIZE		DIMENSIONS						WEIGHT		STUD DETAILS						
NPS	DN	B		A		D		Lbs	Kgs	No.	DIAMETER		STUD LENGTH (RF)		STUD LENGTH (RTJ)	
		in	mm	in	mm	in	mm				in	mm	in	mm	in	mm
2"	50	2.76	70	5.51	140	2.17	55	5	2.2	8	7/8"	M24	8.86	225	9.06	230
2-1/2"	65	3.27	83	6.38	162	2.68	68	7	3.1	8	1"	M27	9.84	250	10.04	255
3"	80	3.27	83	6.77	172	3.23	82	9	4.3	8	7/8"	M24	10.63	270	10.83	275
4"	100	4.02	102	8.19	208	4.25	108	14	6.3	8	1-1/4"	M33	12.2	310	12.4	315
5"	125	4.33	110	10.12	257	5.12	130	18	8.4	8	1-1/2"	M39	14.57	370	14.76	375
6"	150	6.26	159	11.06	281	5.91	150	28	12.6	12	1-3/8"	M36	16.93	430	17.32	440
8"	200	8.11	206	13.78	350	7.87	200	53	24	12	1-5/8"	M42	20.08	510	20.47	520
10"	250	9.76	248	17.05	433	9.84	250	88	40	12	1-7/8"	M48	23.62	600	24.02	610
12"	300	12.01	305	20.39	518	11.81	300	145	66	16	2"	M52	27.36	695	27.95	710
14"	350	14.02	356	22.68	576	12.6	320	183	83	16	2-1/4"	M56	30.51	775	31.1	790
16"	400	15.12	384	25.2	640	14.17	360	224	102	16	2-1/2"	M64	33.46	850	34.25	870
18"	450	18.43	468	27.68	703	16.54	420	273	124	16	2-3/4"	M70	38.19	970	38.98	990
20"	500	20.98	533	29.69	754	18.5	470	330	150	16	3"	M76	42.52	1080	43.31	1100
24"	600	22.01	559	35.35	898	22.44	570	447	203	16	3-1/2"	M88	46.85	1190	47.64	1210

**MODEL 362500 / 362509**

Dimensions & Weights - Wafer Type - ASME Class 2500

SIZE		DIMENSIONS						WEIGHT		STUD DETAILS						
NPS	DN	B		A		D		Lbs	Kgs	No.	DIAMETER		STUD LENGTH (RF)		STUD LENGTH (RTJ)	
		in	mm	in	mm	in	mm				in	mm	in	mm	in	mm
2"	50	2.76	70	5.63	143	2.17	55	5	2.2	8	1"	M27	10.04	255	10.24	260
2-1/2"	65	3.27	83	6.54	166	2.68	68	7	3.1	8	1-1/8"	M30	11.42	290	11.81	300
3"	80	3.39	86	7.64	194	3.23	82	9	4.3	8	1-1/4"	M33	12.6	320	12.99	330
4"	100	4.13	105	9.13	232	4.25	108	14	6.3	8	1-1/2"	M39	14.57	370	14.96	380
5"	125	4.33	110	10.91	277	5.12	130	18	8.4	8	1-3/4"	M45	16.54	420	17.13	435
6"	150	6.26	159	12.44	316	6.1	155	28	12.6	8	2"	M52	20.28	515	20.87	530
8"	200	8.11	206	15.2	386	8.07	205	53	24	12	2"	M52	23.62	600	24.41	620
10"	250	10	254	18.7	475	9.65	245	88	40	12	2-1/2"	M64	29.53	750	30.51	775
12"	300	12.01	305	21.57	548	11.42	290	145	66	12	2-3/4"	M70	33.66	855	34.84	885

## WAFER TYPE DUAL PLATE CHECK VALVE

**Construction:** Dual plate check valves, Wafer type, Retainer less design, Spring loaded, Horizontal or Vertical positions.

### Dimensions

Face to Face	API 6A
End Flange	API 6A
Rating	API 6A Class 2000-5000

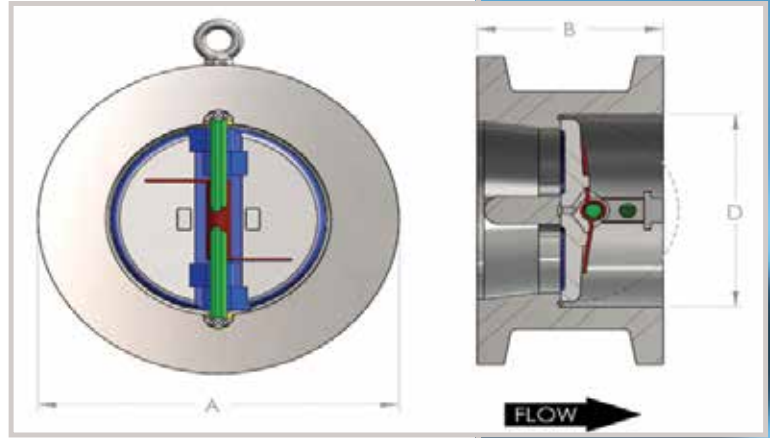

## MODEL 362000 / 362009

Dimensions & Weights - Wafer Type - API 6A Class 2000

SIZE	DIMENSIONS						WEIGHT		No.	STUD DETAILS					
	B		A		D					DIAMETER		STUD LENGTH (RF)		STUD LENGTH (RTJ)	
	NPS	in	mm	in	mm	in	mm	Lbs		Kgs	in	mm	in	mm	in
2-1/16"	6.5	165	2.36	60	2.36	60	18	8.1	8	5/8"	M16	3.27	83	3.74	95
2-9/16"	7.52	191	2.64	67	2.87	73	28	12.9	8	3/4"	M20	3.74	95	4.02	102
3-1/8"	8.27	210	2.87	73	2.91	74	33	14.8	8	3/4"	M20	3.74	95	4.25	108
4-1/16"	10.75	273	3.11	79	4.49	114	90	41	8	7/8"	M24	4.25	108	4.76	121
5-1/8"	12.99	330	4.02	102	5.55	141	130	59	8	1"	M27	5	127	5.24	133
7-1/16"	14.02	356	5.39	137	6.61	168	169	77	12	1"	M27	5	127	5.51	140
9"	16.5	419	6.5	165	8.62	219	315	143	12	1-1/8"	M30	5.75	146	5.98	152
11"	20	508	8.39	213	10.75	273	517	235	16	1-1/4"	M33	6.26	159	6.73	171
13-5/8"	22.01	559	9.02	229	12.76	324	552	251	20	1-1/4"	M33	6.5	165	6.73	171
16-3/4"	27.01	686	12.01	305	15.98	406	1012	460	20	1-1/2"	M39	7.52	191	7.76	197
20-3/4"	32.01	813	14.49	368	20	508	1694	770	24	1-5/8"	M42	8.27	210	9.02	229

## MODEL 363000 / 363009

Dimensions & Weights - Wafer Type - API 6A Class 3000

SIZE	DIMENSIONS						WEIGHT		No.	STUD DETAILS					
	B		A		D					DIAMETER		STUD LENGTH (RF)		STUD LENGTH (RTJ)	
	NPS	in	mm	in	mm	in	mm	Lbs		Kgs	in	mm	in	mm	in
2-1/16"	8.5	216	2.76	70	2.36	60	40	18	8	7/8"	M24	4.25	108	4.76	121
2-9/16"	9.61	244	3.27	83	2.87	73	66	30	8	1"	M27	4.76	121	5.24	133
3-1/8"	9.49	241	3.27	83	2.91	74	64	29	8	7/8"	M24	4.02	102	4.49	114
4-1/16"	11.5	292	4.02	102	4.49	114	99	45	8	1-1/8"	M30	5	127	5.51	140
5-1/8"	13.74	349	5.24	133	5.55	141	191	87	8	1-1/4"	M33	5.51	140	5.98	152
7-1/16"	15	381	6.26	159	6.61	168	257	117	12	1-1/8"	M30	5.24	133	5.75	146
9"	18.5	470	8.11	206	8.62	219	482	219	12	1-3/8"	M36	6.26	159	6.73	171
11"	21.5	546	9.49	241	10.75	273	726	330	16	1-3/8"	M36	6.5	165	7.01	178
13-5/8"	24.02	610	11.5	292	12.76	324	770	350	20	1-3/8"	M36	6.73	171	7.24	184
16-3/4"	27.76	705	15.12	384	15.98	406	1210	550	20	1-5/8"	M42	7.76	197	8.5	216
20-3/4"	33.74	857	17.76	451	20	508	3865	1757	20	2"	M51	9.25	235	10	254

## MODEL 365000 / 365009

Dimensions & Weights - Wafer Type - API 6A Class 5000

SIZE	DIMENSIONS						WEIGHT		No.	STUD DETAILS					
	B		A		D					DIAMETER		STUD LENGTH (RF)		STUD LENGTH (RTJ)	
	NPS	in	mm	in	mm	in	mm	Lbs		Kgs	in	mm	in	mm	in
2-1/16"	8.5	216	2.76	70	2.36	60	37	17	8	7/8"	M24	4.25	108	4.76	121
2-9/16"	9.61	244	3.27	83	2.87	73	66	30	8	1"	M27	4.76	121	5.24	133
3-1/8"	10.51	267	3.27	83	2.91	74	68	31	8	1-1/8"	M30	5.24	133	5.75	146
4-1/16"	12.24	311	4.02	102	4.49	114	154	70	8	1-1/4"	M33	5.98	152	6.26	159
5-1/8"	14.76	375	5.24	133	5.55	141	231	105	8	1-1/2"	M39	7.24	184	7.76	197
7-1/16"	15.51	394	6.26	159	6.61	168	268	122	12	1-3/8"	M36	7.24	184	7.76	197
9"	19.02	483	8.11	206	8.62	219	627	285	12	1-5/8"	M42	8.27	210	9.02	229
11"	22.99	584	9.76	248	10.75	273	792	360	12	1-7/8"	M48	9.49	241	10.24	260

**SOLID LUG DUAL PLATE CHECK VALVE**

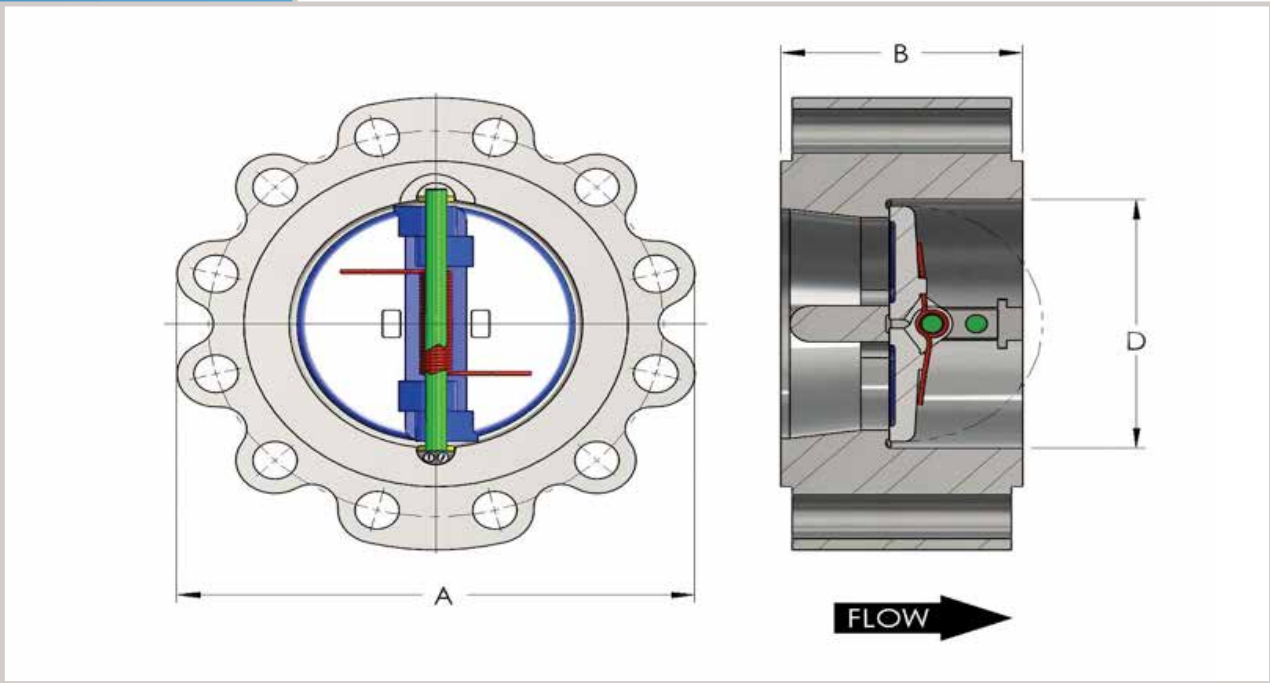

**Construction:** Dual plate check valves, Lug type, Retainer less design, Spring loaded, Horizontal or Vertical positions.

**Dimensions**

Face to Face	ASME B16.10
End Flange	ASME B16.5*
Rating	ASME Class 150-2500

\*26" and larger are available with ASME B16.47 end flanges, either Series A or Series B (formerly MSS SP-44 and API 605.)

**MODEL 37150 / 38150**

Dimensions & Weights - Lug Type - ASME Class 150

SIZE		DIMENSIONS						WEIGHT		STUD DETAILS				
		B		A		D				No.	DIAMETER		STUD LENGTH (RF)	
NPS	DN	in	mm	in	mm	in	mm	Lbs	Kgs		in	mm	in	mm
1-1/2"	40	2.36	60	5	127	1.65	42	6	2.5	4	1/2"	M12	5.12	130
2"	50	2.36	60	5.98	152	2.17	55	8	3.5	4	5/8"	M16	5.51	140
2-1/2"	65	2.64	67	7.01	178	2.68	68	11	5	4	5/8"	M16	5.91	150
3"	80	2.87	73	7.48	190	3.23	82	15	7	4	5/8"	M16	6.3	160
4"	100	2.87	73	9.02	229	4.25	108	22	10	8	5/8"	M16	6.69	170
5"	125	3.39	86	10	254	5.12	130	30	13.5	8	3/4"	M20	7.48	190
6"	150	3.86	98	10.98	279	6.5	165	44	20	8	3/4"	M20	8.07	205
8"	200	5	127	13.5	343	8.66	220	85	38.5	8	3/4"	M20	9.45	240
10"	250	5.75	146	15.98	406	10.63	270	150	68	12	7/8"	M24	10.63	270
12"	300	7.13	181	18.82	478	12.6	320	253	115	12	7/8"	M24	12.2	310
14"	350	7.24	184	20.98	533	13.78	350	341	155	12	1"	M27	12.8	325
16"	400	7.52	191	23.5	597	15.75	400	422	192	16	1"	M27	13.39	340
18"	450	7.99	203	25	635	17.24	438	717	326	16	1-1/8"	M30	14.37	365
20"	500	8.62	219	27.28	693	19.49	495	627	285	20	1-1/8"	M30	15.16	385
24"	600	8.74	222	31.89	810	23.43	595	847	385	20	1-1/4"	M33	15.94	405

**SOLID LUG DUAL PLATE CHECK VALVE**

**MODEL 37300 / 38300**

Dimensions & Weights - Lug Type - ASME Class 300

SIZE		DIMENSIONS						WEIGHT		STUD DETAILS				
NPS	DN	B		A		D		Lbs	Kgs	No.	DIAMETER		STUD LENGTH (RF)	
		in	mm	in	mm	in	mm				in	mm	in	mm
1-1/2"	40	2.36	60	6.14	156	1.65	42	7	3	4	3/4"	M20	6.3	160
2"	50	2.36	60	6.38	162	2.17	55	9	4.2	8	5/8"	M16	6.1	155
2-1/2"	65	2.64	67	7.4	188	2.68	68	15	6.8	8	3/4"	M20	6.89	175
3"	80	2.87	73	8.19	208	3.23	82	19	8.5	8	3/4"	M20	7.48	190
4"	100	2.87	73	9.53	242	4.25	108	26	12	8	3/4"	M20	7.68	195
5"	125	3.39	86	10.98	279	5.12	130	42	19	8	3/4"	M20	8.46	215
6"	150	3.86	98	12.05	306	6.5	165	62	28	12	3/4"	M20	9.06	230
8"	200	5	127	14.72	374	8.66	220	128	58	12	7/8"	M24	11.02	280
10"	250	5.75	146	17.24	438	10.63	270	202	92	16	1"	M27	12.4	315
12"	300	7.13	181	20.16	512	12.6	320	337	153	16	1-1/8"	M30	14.37	365
14"	350	8.74	222	22.72	577	13.5	343	484	220	20	1-1/8"	M30	16.14	410
16"	400	9.13	232	23.07	586	15.75	400	682	310	20	1-1/4"	M33	17.13	435
18"	450	10.39	264	27.24	692	17.24	438	858	390	24	1-1/4"	M33	18.7	475
20"	500	11.5	292	29.61	752	19.49	495	1254	570	24	1-1/4"	M33	20.08	510
24"	600	12.52	318	31.89	810	23.43	595	1672	760	24	1-1/2"	M39	22.05	560

**MODEL 37600 / 37609 / 38600 / 38609**

Dimensions & Weights - Lug Type - ASME Class 600

SIZE		DIMENSIONS						WEIGHT		STUD DETAILS						
NPS	DN	B		A		D		Lbs	Kgs	No.	DIAMETER		STUD LENGTH (RF)		STUD LENGTH (RTJ)	
		in	mm	in	mm	in	mm				in	mm	in	mm	in	mm
2"	50	2.36	60	6.38	162	2.17	55	9	4.2	8	5/8"	M16	6.89	175	7.09	180
2-1/2"	65	2.64	67	7.68	195	2.68	68	15	6.8	8	3/4"	M20	7.68	195	7.87	200
3"	80	2.87	73	8.19	208	3.23	82	19	8.5	8	3/4"	M20	8.27	210	8.46	215
4"	100	3.11	79	10.24	260	4.25	108	37	17	8	7/8"	M24	9.25	235	9.45	240
5"	125	4.13	105	11.02	280	5.12	130	59	27	8	1"	M27	11.02	280	11.22	285
6"	150	5.35	136	13.46	342	6.5	165	112	51	12	1"	M27	12.6	320	12.8	325
8"	200	6.5	165	15.75	400	8.27	210	200	91	12	1-1/8"	M30	14.57	370	14.76	375
10"	250	8.39	213	19.21	488	10.04	255	411	187	16	1-1/4"	M33	17.32	440	17.52	445
12"	300	9.02	229	21.81	554	11.81	300	504	229	20	1-1/4"	M33	18.11	460	18.31	465
14"	350	10.75	273	22.6	574	13.19	335	823	374	20	1-3/8"	M36	20.47	520	20.67	525
16"	400	12.01	305	26.46	672	15.16	385	1148	522	20	1-1/2"	M39	22.64	575	22.83	580
18"	450	14.25	362	28.58	726	17.13	435	1430	650	20	1-5/8"	M42	25.59	650	25.79	655
20"	500	14.49	368	31.5	800	19.17	487	1474	670	24	1-5/8"	M42	26.38	670	26.77	680
24"	600	17.24	438	36.3	922	23.03	585	1716	780	24	1-7/8"	M48	30.71	780	31.1	790

**MODEL 37900 / 37909 / 38900 / 38909**

Dimensions & Weights - Lug Type - ASME Class 900

SIZE		DIMENSIONS						WEIGHT		STUD DETAILS						
NPS	DN	B		A		D		Lbs	Kgs	No.	DIAMETER		STUD LENGTH (RF)		STUD LENGTH (RTJ)	
		in	mm	in	mm	in	mm				in	mm	in	mm	in	mm
2"	50	2.76	70	8.27	210	2.17	55	26	12	8	7/8"	M24	8.86	225	9.06	230
2-1/2"	65	3.27	83	9.21	234	2.68	68	33	15	8	1"	M27	9.84	250	10.04	255
3"	80	3.27	83	9.21	234	3.23	82	42	19	8	7/8"	M24	9.45	240	9.65	245
4"	100	4.02	102	11.5	292	4.25	108	75	34	8	1-1/8"	M30	11.22	285	11.42	290
5"	125	4.33	110	13.19	335	5.12	130	123	56	8	1-1/4"	M33	12.2	310	12.4	315
6"	150	6.26	159	14.96	380	6.3	160	180	82	12	1-1/8"	M30	14.37	365	14.57	370
8"	200	8.11	206	18.03	458	8.27	210	352	160	12	1-3/8"	M36	17.32	440	17.52	445
10"	250	9.49	241	20.87	530	10.04	255	594	270	16	1-3/8"	M36	19.29	490	19.49	495
12"	300	11.5	292	23.39	594	11.81	300	933	424	20	1-3/8"	M36	22.05	560	22.24	565
14"	350	14.02	356	24.61	625	12.8	325	1474	670	20	1-1/2"	M39	25.39	645	25.79	655
16"	400	15.12	384	27.24	692	14.96	380	1738	790	20	1-5/8"	M42	26.97	685	27.36	695
18"	450	17.76	451	30.31	770	16.73	425	2640	1200	20	1-7/8"	M48	31.1	790	31.5	800
20"	500	17.76	451	33.07	840	18.7	475	3564	1620	20	2"	M52	31.89	810	32.28	820
24"	600	19.49	495	39.76	1010	22.44	570	4532	2060	20	2-1/2"	M64	37.2	945	37.6	955

DIMENSIONS IN INCHES

**SOLID LUG DUAL PLATE CHECK VALVE**

**MODEL 371500 / 371509 / 381500 / 381509**

Dimensions & Weights - Lug Type - ASME Class 1500

SIZE		DIMENSIONS						WEIGHT		STUD DETAILS						
NPS	DN	B		A		D		Lbs	Kgs	No.	DIAMETER		STUD LENGTH (RF)		STUD LENGTH (RTJ)	
		in	mm	in	mm	in	mm				in	mm	in	mm		
2"	50	2.76	70	8.27	210	2.17	55	26	12	8	7/8"	M24	8.86	225	9.06	230
2-1/2"	65	3.27	83	9.21	234	2.68	68	53	24	8	1"	M27	9.84	250	10.04	255
3"	80	3.27	83	10.04	255	3.23	82	70	32	8	7/8"	M24	10.63	270	10.83	275
4"	100	4.02	102	11.5	292	4.25	108	132	60	8	1-1/4"	M33	12.2	310	12.4	315
5"	125	4.33	110	13.98	355	5.12	130	229	104	8	1-1/2"	M39	14.37	365	14.76	375
6"	150	6.26	159	15.2	386	5.91	150	286	130	12	1-3/8"	M36	16.93	430	17.32	440
8"	200	8.11	206	18.7	475	7.87	200	546	248	12	1-5/8"	M42	20.08	510	20.47	520
10"	250	9.76	248	22.24	565	9.84	250	981	446	12	1-7/8"	M48	23.62	600	24.02	610
12"	300	12.01	305	25.98	660	11.81	300	1738	790	16	2"	M52	27.36	695	27.95	710

**MODEL 372500 / 372509 / 382500 / 382509**

Dimensions & Weights - Lug Type - ASME Class 2500

SIZE		DIMENSIONS						WEIGHT		STUD DETAILS						
NPS	DN	B		A		D		Lbs	Kgs	No.	DIAMETER		STUD LENGTH (RF)		STUD LENGTH (RTJ)	
		in	mm	in	mm	in	mm				in	mm	in	mm		
2"	50	2.76	70	8.86	225	2.17	55	40	18	8	1"	M27	10.04	255	10.24	260
2-1/2"	65	3.27	83	10.04	255	2.68	68	53	24	8	1-1/8"	M30	11.42	290	11.81	300
3"	80	3.39	86	11.42	290	3.23	82	70	32	8	1-1/4"	M33	12.6	320	12.99	330
4"	100	4.13	105	13.58	345	4.25	108	132	60	8	1-1/2"	M39	14.57	370	14.96	380
5"	125	4.33	110	15.83	402	5.12	130	229	104	8	1-3/4"	M45	16.54	420	17.13	435
6"	150	6.26	159	17.8	452	6.1	155	286	130	8	2"	M52	20.28	515	20.87	530
8"	200	8.11	206	20.67	525	8.07	205	546	248	12	2"	M52	23.62	600	24.41	620
10"	250	10	254	25.39	645	9.65	245	981	446	12	2-1/2"	M64	29.53	750	30.51	775
12"	300	12.01	305	28.74	730	11.42	290	1738	790	12	2-3/4"	M70	33.66	855	34.84	885

**DOUBLE FLANGE TYPE DUAL PLATE CHECK VALVE**

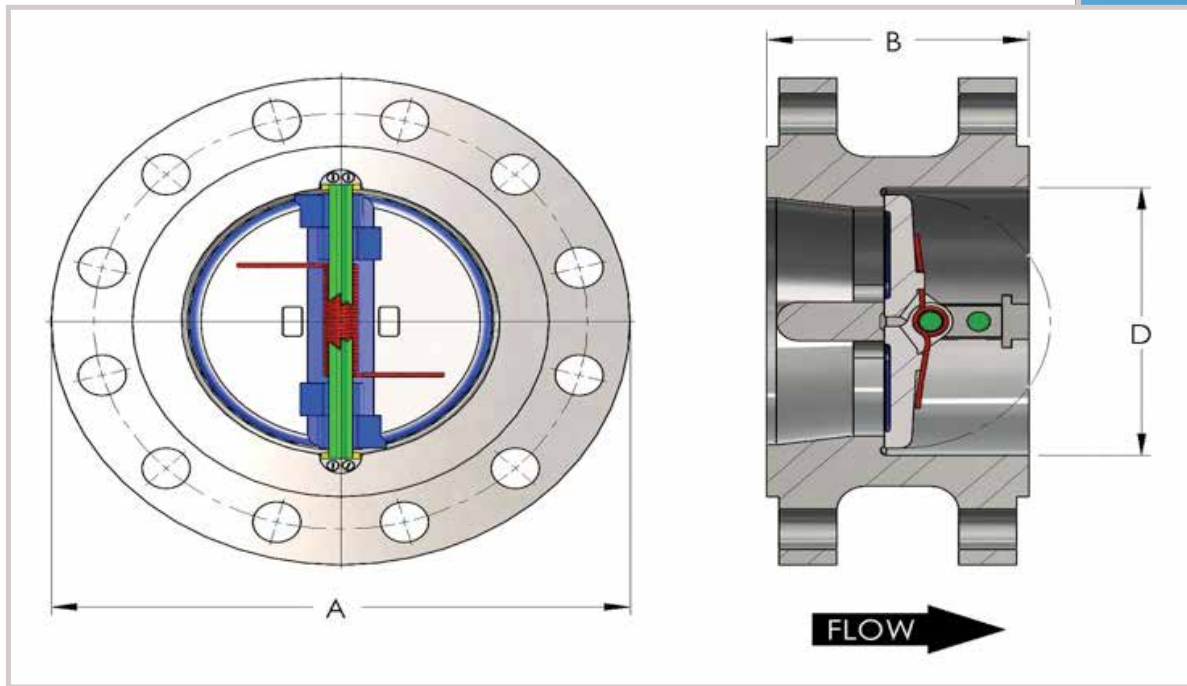

**Construction:** Dual plate check valves, Flange type, Retainer less design, Spring loaded, Horizontal or Vertical positions.

**Dimensions**

Face to Face	ASME B16.10
End Flange	ASME B16.5*
Rating	ASME Class 150-2500

\*26" and larger are available with ASME B16.47 end flanges, either Series A or Series B (formerly MSS SP-44 and API 605.)

**MODEL 39150**

**Dimensions & Weights - Flange Type - ASME Class 150**

SIZE		DIMENSIONS						WEIGHT		No.	STUD DETAILS			
		B		A		D					DIAMETER		STUD LENGTH (RF)	
NPS	DN	in	mm	in	mm	in	mm	Lbs	Kgs		in	mm	in	mm
8"	200	5	127	13.5	343	8.66	220	68	31	8	3/4"	M20	4.72	120
10"	250	5.75	146	15.98	406	10.63	270	114	52	12	7/8"	M24	5.31	135
12"	300	7.13	181	19.02	483	12.6	320	189	86	12	7/8"	M24	5.31	135
14"	350	7.24	184	20.98	533	13.78	350	238	108	12	1"	M27	5.71	145
16"	400	7.52	191	23.5	597	15.75	400	293	133	16	1"	M27	5.91	150
18"	450	7.99	203	25	635	17.24	438	354	161	16	1-1/8"	M30	6.3	160
20"	500	8.62	219	27.52	699	19.49	495	429	195	20	1-1/8"	M30	6.5	165
24"	600	8.74	222	32.01	813	23.43	595	579	263	20	1-1/4"	M33	7.09	180
28"	700	12.01	305	36.5	927	26.97	685	1087	494	28	1-1/4"	M33	9.06	230
30"	750	12.01	305	38.74	984	28.94	735	1179	536	28	1-1/4"	M33	9.45	240
32"	800	12.01	305	41.73	1060	30.71	780	1659	754	28	1-1/2"	M39	10.43	265
36"	900	14.49	368	45.98	1168	34.45	875	1901	864	32	1-1/2"	M39	11.22	285
40"	1000	17.01	432	50.75	1289	38.39	975	2517	1144	36	1-1/2"	M39	11.22	285
42"	1050	17.01	432	52.99	1346	40.16	1020	2853	1297	36	1-1/2"	M39	11.61	295
48"	1200	20.63	524	59.49	1511	45.87	1165	4204	1911	44	1-1/2"	M39	12.6	320
54"	1350	22.36	568	66.26	1683	51.97	1320	6006	2730	44	1-3/4"	M45	14.17	360
60"	1500	24.76	629	72.99	1854	57.48	1460	8437	3835	52	1-3/4"	M45	15.16	385

**DOUBLE FLANGE TYPE DUAL PLATE CHECK VALVE**

**MODEL 39300**

Dimensions & Weights - Flange Type - ASME Class 300

SIZE		DIMENSIONS						WEIGHT		STUD DETAILS					
NPS	DN	B		A		D		Lbs	Kgs	No.	DIAMETER		STUD LENGTH (RF)		
		in	mm	in	mm	in	mm				in	mm	in	mm	
12"	300	7.13	181	20.51	521	12.6	320	231	105	16	1-1/8"	M30	7.09	180	
14"	350	8.74	222	22.99	584	13.5	343	334	152	20	1-1/8"	M30	7.28	185	
16"	400	9.13	232	25.51	648	15.75	400	451	205	20	1-1/4"	M33	7.87	200	
18"	450	10.39	264	27.99	711	17.24	438	572	260	24	1-1/4"	M33	8.27	210	
20"	500	11.5	292	30.51	775	19.49	495	814	370	24	1-1/4"	M33	8.46	215	
24"	600	12.52	318	35.98	914	23.43	595	1087	494	24	1-1/2"	M39	9.45	240	
28"	700	14.49	368	40.75	1035	26.97	685	1674	761	28	1-5/8"	M42	11.02	280	
30"	750	14.49	368	42.99	1092	28.94	735	1991	905	28	1-5/4"	M45	11.81	300	
32"	800	14.49	368	45.24	1149	30.71	780	2820	1282	28	1-7/8"	M48	13.19	335	
36"	900	19.02	483	50	1270	34.45	875	3060	1391	32	2"	M51	13.58	345	
40"	1000	22.36	568	48.74	1238	38.39	975	3775	1716	32	1-5/8"	M42	13.39	340	
42"	1050	22.36	568	50.75	1289	40.16	1020	4290	1950	32	1-5/8"	M42	13.78	350	
48"	1200	24.76	629	57.76	1467	45.87	1165	6435	2925	32	1-7/8"	M48	15.35	390	
54"	1350	25	635	65.24	1657	51.97	1320	9610	4368	28	2-1/4"	M57	18.11	460	
60"	1500	27.6	701	71.26	1810	57.48	1460	12654	5752	32	2-1/4"	M57	18.9	480	

**MODEL 39600 / 39609**

Dimensions & Weights - Flange Type - ASME Class 600

SIZE		DIMENSIONS						WEIGHT		STUD DETAILS						
NPS	DN	B		A		D		Lbs	Kgs	No.	DIAMETER		STUD LENGTH (RF)		STUD LENGTH (RTJ)	
		in	mm	in	mm	in	mm				in	mm	in	mm	in	mm
12"	300	9.02	229	22.01	559	11.81	300	352	160	20	1-1/4"	M33	8.66	220	8.86	225
14"	350	10.75	273	23.74	603	13.19	335	576	262	20	1-3/8"	M36	9.25	235	9.45	240
16"	400	12.01	305	27.01	686	15.16	385	803	365	20	1-1/2"	M39	10.04	255	10.24	260
18"	450	14.25	362	29.25	743	17.13	435	1124	511	20	1-5/8"	M42	10.83	275	11.02	280
20"	500	14.49	368	32.01	813	19.17	487	1397	635	24	1-5/8"	M42	11.22	285	11.42	290
24"	600	17.24	438	37.01	940	23.03	585	2171	987	24	1-7/8"	M48	12.99	330	13.19	335
28"	700	19.88	505	42.24	1073	26.97	685	3065	1393	28	2"	M51	14.17	360	14.37	365
30"	750	19.88	505	44.49	1130	28.94	735	3634	1652	28	2"	M51	14.37	365	14.57	370
32"	800	19.88	505	47.01	1194	30.71	780	5159	2345	28	2-1/4"	M57	15.16	385	15.35	390
36"	900	25	635	51.73	1314	34.45	875	6499	2954	28	2-1/2"	M64	16.54	420	16.54	420
40"	1000	27.6	701	52.01	1321	38.39	975	6915	3143	32	2-1/4"	M57	18.5	470	18.5	470
42"	1050	27.6	701	55.24	1403	40.16	1020	7854	3570	28	2-1/2"	M64	20.08	510	20.08	510
48"	1200	30.98	787	57.76	1467	45.87	1165	11796	5362	32	2-3/4"	M70	22.24	565	22.24	565

**MODEL 39900 / 39909**

Dimensions & Weights - Flange Type - ASME Class 900

SIZE		DIMENSIONS						WEIGHT		STUD DETAILS						
NPS	DN	B		A		D		Lbs	Kgs	No.	DIAMETER		STUD LENGTH (RF)		STUD LENGTH (RTJ)	
		in	mm	in	mm	in	mm				in	mm	in	mm	in	mm
12"	300	11.5	292	24.02	610	11.81	300	651	296	20	1-3/8"	M36	10.04	255	10.24	260
14"	350	14.02	356	25.2	640	12.8	325	1032	469	20	1-1/2"	M39	11.02	280	11.22	285
16"	400	15.12	384	27.76	705	14.96	380	1217	553	20	1-5/8"	M42	11.61	295	11.81	300
18"	450	17.76	451	30.91	785	16.73	425	1848	840	20	1-7/8"	M48	13.19	335	13.39	340
20"	500	17.76	451	33.66	855	18.7	475	2495	1134	20	2"	M52	14.17	360	14.37	365
24"	600	19.49	495	40.94	1040	22.44	570	3172	1442	20	2-1/2"	M64	17.72	450	17.91	455
28"	700	22.01	559	45.98	1168	26.38	670	4466	2030	20	3"	M76	18.9	480	19.09	485
30"	750	22.01	559	48.5	1232	28.15	715	5606	2548	20	3"	M76	19.69	500	19.88	505
32"	800	22.01	559	61.38	1559	29.92	760	6468	2940	20	3-1/4"	M82	21.06	535	21.26	540
36"	900	27.6	701	57.48	1460	33.86	860	10010	4550	20	3-1/2"	M88	22.44	570	22.64	575



**PRESSURE/TEMPERATURE RATING ASME B16.34-2009**

**COLD WORKING PRESSURE, psig**

CLASS	TEMP °F	A216 WCB A105 & LF2	A352 LCC	A217 WC6 A182 F11	A217 WC9 A182 F22	A217 C5 A182 F5	A217 C12 A182 F9	A351 CF8 A182 F304	A351 CF8M A182 F316	A352 CN7M	
150	-20 to 100	285	290	290	290	290	290	275	275	230	
	200	260	260	260	260	260	260	230	230	200	
	300	230	230	230	230	230	230	205	205	180	
	400	200	200	200	200	200	200	190	190	160	
	500	170	170	170	170	170	170	170	170	150	
	600	140	140	140	140	140	140	140	140	140	
	650	125	125	125	125	125	125	125	125		
	700	110	110	110	110	110	110	110	110		
	750	95	95	95	95	95	95	95	95		
	800	80	80	80	80	80	80	80	80		
	850	65	65	65	65	65	65	65	65		
	900	50	50	50	50	50	50	50	50		
	950	35	35	35	35	35	35	35	35		
	1000	20	20	20	20	20	20	20	20		
	1050				20 (a)	20 (a)	20 (a)	20 (a)	20(a)	20(a)	
	1100				20 (a)	20 (a)	20 (a)	20 (a)	20(a)	20(a)	
	1150				20 (a)	20 (a)	20 (a)	20 (a)	20(a)	20(a)	
	1200				15 (a)	15 (a)	15 (a)	20 (a)	20(a)	20(a)	
	1250								20(a)	20(a)	
	1300								20(a)	20(a)	
1350								20(a)	20(a)		
1400								20(a)	20(a)		
1450								20(a)	20(a)		
1500								15(a)	15(a)		
CLASS	TEMP °F	A216 WCB A105 & LF2	A352 LCC	A217 WC6 A182 F11	A217 WC9 A182 F22	A217 C5 A182 F5	A217 C12 A182 F9	A351 CF8 A182 F304	A351 CF8M A182 F316	A352 CN7M	
300	-20 to 100	740	750	750	750	750	750	720	720	600	
	200	680	750	750	750	750	750	600	620	520	
	300	655	730	720	730	730	730	540	560	465	
	400	635	705	695	705	705	705	495	515	420	
	500	605	665	665	665	665	665	465	480	390	
	600	570	605	605	605	605	605	440	450	360	
	650	550	590	590	590	590	590	430	440		
	700	530	555	570	570	570	570	420	435		
	750	505	505	530	530	530	530	415	425		
	800	410	410	510	510	510	510	405	420		
	850	320	320	485	485	485	485	395	420		
	900	230	225	450	450	375	450	390	415		
	950	135	135	320	385	275	375	380	385		
	1000	85	85	215	265	200	255	355	365		
	1050			145	175	145	170	325	360		
	1100			95	110	100	115	255	305		
	1150			65	70	60	75	205	235		
	1200			40	40	35	50	165	185		
	1250							135	145		
	1300							115	115		
1350							95	95			
1400							75	75			
1450							60	60			
1500							40	40			

A - Permissible, but not recommended for prolonged usage

**PRESSURE/TEMPERATURE RATING ASME B16.34-2009**

**COLD WORKING PRESSURE, psig**

CLASS	TEMP °F	A216 WCB A105 & LF2	A352 LCC	A217 WC6 A182 F11	A217 WC9 A182 F22	A217 C5 A182 F5	A217 C12 A182 F9	A351 CF8 A182 F304	A351 CF8M A182 F316	A352 CN7M
600	-20 to 100	1480	1500	1500	1500	1500	1500	1440	1440	1200
	200	1360	1500	1500	1500	1500	1500	1200	1240	1035
	300	1310	1455	1445	1455	1455	1455	1075	1120	930
	400	1265	1405	1385	1410	1410	1410	995	1025	845
	500	1205	1330	1330	1330	1330	1330	930	955	780
	600	1135	1210	1210	1210	1210	1210	885	900	720
	650	1100	1175	1175	1175	1175	1175	865	885	
	700	1060	1110	1135	1135	1135	1135	845	870	
	750	1015	1015	1065	1065	1065	1065	825	855	
	800	825	825	1015	1015	1015	1015	810	845	
	850	640	640	975	975	975	975	790	835	
	900	460	445	900	900	745	900	780	830	
	950	275	275	640	755	550	755	765	775	
	1000	170	170	430	535	400	505	710	725	
	1050			290	350	290	345	650	720	
	1100			190	220	200	225	515	610	
	1150			130	135	125	150	410	475	
	1200			80	80	70	105	330	370	
1250							265	295		
1300							225	235		
1350							185	190		
1400							150	150		
1450							115	115		
1500							85	85		
CLASS	TEMP °F	A216 WCB A105 & LF2	A352 LCC	A217 WC6 A182 F11	A217 WC9 A182 F22	A217 C5 A182 F5	A217 C12 A182 F9	A351 CF8 A182 F304	A351 CF8M A182 F316	A352 CN7M
900	-20 to 100	2200	2250	2250	2250	2250	2250	2160	2160	1800
	200	2035	2250	2250	2250	2250	2250	1800	1860	1555
	300	1965	2185	2165	2185	2185	2185	1615	1680	1395
	400	1900	2110	2080	2115	2115	2115	1490	1540	1265
	500	1810	1995	1995	1995	1995	1995	1395	1435	1165
	600	1705	1815	1815	1815	1815	1815	1325	1355	1080
	650	1650	1765	1765	1765	1765	1765	1295	1325	
	700	1590	1665	1705	1705	1705	1705	1265	1305	
	750	1520	1520	1595	1595	1595	1595	1240	1280	
	800	1235	1235	1525	1525	1525	1525	1215	1265	
	850	955	955	1460	1460	1460	1460	1190	1255	
	900	690	670	1350	1350	1120	1350	1165	1245	
	950	410	410	955	1160	825	1130	1145	1160	
	1000	255	255	650	800	595	760	1065	1090	
	1050			430	525	430	515	975	1080	
	1100			290	330	300	340	770	915	
	1150			195	205	185	225	615	710	
	1200			125	125	105	155	495	555	
1250							400	440		
1300							340	350		
1350							280	290		
1400							225	225		
1450							175	175		
1500							125	125		

**PRESSURE/TEMPERATURE RATING ASME B16.34-2009**

**COLD WORKING PRESSURE, psig**

CLASS	TEMP °F	A216 WCB A105 & LF2	A352 LCC	A217 WC6 A182 F11	A217 WC9 A182 F22	A217 C5 A182 F5	A217 C12 A182 F9	A351 CF8 A182 F304	A351 CF8M A182 F316	A352 CN7M
1500	-20 to 100	3705	3750	3750	3750	3750	3750	3600	3600	3000
	200	3395	3750	3750	3750	3750	3750	3000	3095	3590
	300	3270	3640	3610	3640	3640	3640	2690	2795	2330
	400	3170	3520	3465	3530	3530	3530	2485	2570	2110
	500	3015	3325	3325	3325	3325	3325	2330	2390	1945
	600	2840	3025	3025	3025	3025	3025	2210	2255	1800
	650	2745	2940	2940	2940	2940	2940	2160	2210	
	700	2665	2775	2840	2840	2840	2840	2110	2170	
	750	2535	2535	2660	2660	2660	2660	2065	2135	
	800	2055	2055	2540	2540	2540	2540	2030	2110	
	850	1595	1595	2435	2435	2435	2435	1980	2090	
	900	1150	1115	2245	2245	1870	2245	1945	2075	
	950	685	685	1595	1930	1370	1885	1910	1930	
	1000	430	430	1080	1335	995	1270	1770	1820	
	1050			720	875	720	855	1630	1800	
	1100			480	550	495	565	1285	1525	
	1150			325	345	310	375	1030	1185	
	1200			205	205	170	255	825	925	
1250							670	735		
1300							565	585		
1350							465	480		
1400							380	380		
1450							290	290		
1500							205	205		
CLASS	TEMP °F	A216 WCB A105 & LF2	A352 LCC	A217 WC6 A182 F11	A217 WC9 A182 F22	A217 C5 A182 F5	A217 C12 A182 F9	A351 CF8 A182 F304	A351 CF8M A182 F316	A352 CN7M
2500	-20 to 100	6170	6250	6250	6250	6250	6250	6000	6000	5000
	200	5655	6250	6250	6250	6250	6250	5000	5160	4320
	300	5450	6070	6015	6070	6070	6070	4480	4660	3880
	400	2280	5865	5775	5880	5880	5880	4140	4280	3520
	500	5025	5540	5540	5540	5540	5540	3880	3980	3240
	600	4730	5040	5040	5040	5040	5040	3680	3760	3000
	650	4575	4905	4905	4905	4905	4905	3600	3680	
	700	4425	4630	4730	4730	4730	4730	3520	3620	
	750	4230	4230	4430	4430	4430	4430	3440	3560	
	800	3430	3430	4230	4230	4230	4230	3380	3520	
	850	2655	2655	4060	4060	4060	4060	3300	3480	
	900	1915	1855	3745	3745	3115	3745	3240	3460	
	950	1145	1145	2655	3220	2285	3145	3180	3220	
	1000	715	715	1800	2230	1655	2115	2950	3030	
	1050			1200	1455	1200	1430	2715	3000	
	1100			800	915	830	945	2145	2545	
	1150			545	570	515	630	1715	1970	
	1200			345	345	285	430	1370	1545	
1250							1115	1230		
1300							945	970		
1350							770	800		
1400							630	630		
1450							485	485		
1500							345	345		



**WORLDWIDE  
HEADQUARTERS  
GWC Italia SpA**

Via A. Grandi, 5  
20056 Trezzo Sull'Adda  
Milano, Italy  
ph: 39-02-86882941  
fax: 39-02-86882942

**USA HEADQUARTERS  
GWC USA, Inc.**

4301 Yeager Way  
Bakersfield,  
California 93313 - USA  
ph: 661-834-1775  
fax: 661-834-2072

[www.gwcitalia.com](http://www.gwcitalia.com)